



www.unisourceparts.com

**GSA PRICING SCHEDULE: PRICE BOOK DATED January 1, 2009**

**GSA Contract Number:– GS-28F-0005u**

**Contract Period – January 16, 2008 – January 15, 2013**

**Special Item Numbers (S.I.N.) 711-1, 711.2**

**Product Offered – Mirage**

**Discount Information – 74.8% off list**

F.O.B. Origin - \$ 0 - \$ 250,000 list

F.O.B. Destination - \$ 250,001 - \$ 500,000 list (48 continental states only)

**Discount is based on January 1, 2009 Price List**

**Minimum Order - \$ 100 net**

**Maximum Order - \$ 500,000 net**

Warranty – Limited lifetime warranty, see price book for details

**Ordering and Payment Information – include participating dealer name on the order:**

**Unisource Office Furniture Parts, Inc.  
7377 Expressway Dr SW Unit D  
Grand Rapids, MI 49548**

**1-616-455-9400 phone**

**1-616-455-9494 fax**

**email: customerservice@unisourceparts.com**

**Federal ID Number – 38-3041442**

**DUNS# - 79 336 6121**

# TERMS AND CONDITIONS

# Mirage Product Lines

## ORDERING

Print Date: January 1, 2009

**Price and Payment** Prices stated in this price list do not include domestic freight. Pricing includes standard packaging only. Orders are invoiced at the time of shipment or at the time of first shipment in the case of multiple shipments. Payment is due within 30 days from date of invoice with approved credit, all other invoices will be due prior to shipment. In some cases, full or partial payment in advance or other adequate assurance of payment is required. Price and specifications subject to change without notice.

**Changes and Cancellations** Any changes or cancellations on standard leadtime products must be in writing and approved by UniSource Office Furniture Parts, Inc. Approved cancellations for products will be subject to a minimum 25% cancellation charge if the request is approved within two weeks of scheduled shipping date. All cancellations must be approved in writing by UniSource Office Furniture Parts, Inc.

**Taxes** If the Purchaser is tax exempt, it is the Purchaser's responsibility to furnish appropriate tax exempt certification. All applicable taxes are the Purchaser's responsibility and will be invoiced to the Purchaser.

## SHIPPING

**Shipment & Delivery** All shipments will be FOB origin, unless otherwise quoted in writing. All orders will be shipped with freight charges added to the invoice. UniSource Office Furniture Parts, Inc. will select the method of shipment, unless otherwise specified by Purchaser. If additional cost is incurred due to Purchaser's special request, the additional cost will be invoiced to Purchaser. All shipping leadtimes are subject to change without notice.

**Storage** In the event Purchaser postpones delivery more than one week after the scheduled shipping date or after the goods have become work-in-progress, the company may transfer the goods to storage at the Purchaser's risk and expense. In such an event, a storage fee will be added to the Purchaser's invoice.

**Returns** In general, all product is custom made to order and is considered non-returnable. Under certain circumstances, UniSource Office Furniture Parts, Inc. may authorize a specific return in writing. To request a return, call the Customer Service Department within 30 days of the invoice date. Once approved, you will receive a return authorization number (RGA #) and return documentaion to accompany the product, and further instructions. To avoid additional product reworking fees, goods must be appropriately packaged to ensure safe return. All returns are subject to a minimum 25% restocking charge, plus any additional freight charges.

**Damage** All product is packaged in an approved manner. It is the customer's responsibility to inspect all merchandise immediately upon receipt. The customer must notify the carrier of the damages immediately. The customer is responsible for filing the freight claim with the delivering carrier within the legal deadlines. UniSource Office Furniture Parts, Inc. must be notified within 5 working days of any shortages, damages or defects which should be apparent by an inspection of the goods. Such notification allows for the prompt replacement of such materials.

## WARRANTY

**Warranty** Uni-Source Office Furniture Parts, Inc. warrants its products to be free from defects in material and workmanship for a limited lifetime of the product from the date of initial delivery, with the following exceptions:

- Five (5) Years - Electrical Products.
- Three (3) Years - High wear parts such as veneers, 3mm & 1-mold edging. All textiles/finishes, glides, keyboard mechanisms, pencil drawers, wood materials.
- Thirty (30) Days - Any Non-Standard or custom products, except COM fabrics. COM fabrics are not warranted in any manner.

This warranty is made by UniSource Office Furniture Parts Inc., only to purchasers acquiring the product directly from UniSource Office Furniture Parts, Inc. or its authorized dealers. UniSource Office Furniture Parts, Inc.'s obligation and the purchaser's remedy pursuant to this warranty are limited to repair or replacement, at UniSource Office Furniture Parts, Inc.'s option, of parts which prove, under normal use, to be defective within the period stated. This remedy is expressly agreed to be exclusive as a condition of such replacement. No person, firm, or corporation is authorized to assume for UniSource Office Furniture Parts, Inc. any other liability in connection with UniSourceOffice Furniture Parts, Inc.'s products.

There are no other warranties except as expressly set forth above, either expressed or implied, including any warranty of merchantability or fitness for any particular purpose. UniSource Office FurnitureParts, Inc.'s liability with respect to its products shall not exceed that expressly set forth above irrespective of the theory upon which any claim might be based including breach of contract, warranty, negligence, or strict liability on tort. Under no circumstances shall UniSource Office Furniture Parts, Inc. be liable for special, incidental, or consequential damages.

This warranty does not apply to damages resulting from shipment, storage, accident, alteration, misuse, assembly or installation. All claims under this warranty must be made in writing prior to the repair or replacement of the product(s).

# TERMS AND CONDITIONS

## PLACING AN ORDER

---

**How to Place An Order** When ordering, please provide the following information in written form:

1. Purchase order number.
2. "Bill To" and "Ship To" name and address.
3. Complete product number. (i.e., HENH.6248DT) MIRAGE

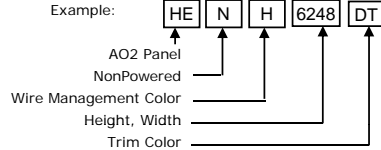

4. Description, including fabric, laminate and trim colors.
5. Quantity.

### Customer's Own Material (COM)

The Customer's Own Material (COM) program gives you the option of using textiles other than those listed in the price book.

1. Refer to the specific product pages in the price book to determine the yardage required for COM textiles.  
Note: Yardage requirements are based on non-directional textiles. 66" wide textiles are needed for application on 60" wide products. Additional yardage may be needed due to the unique characteristics of a textile.
2. An acknowledgement will be sent upon receipt of your completed purchase order. The order processing will start upon the return of the signed order acknowledgement.
3. All COM fabric needs to be pre-approved prior to ordering.
4. Arrangements must be made for the textiles to be shipped from the supplier for application to the products. All textile packages must be tagged with labels that include the purchase order number, Customer Name, and the words: "COM Fabric," along with the assigned identification number and the roll yardage quantity.

### CUSTOMER'S OWN MATERIAL

5. Any delay in delivery of COM fabric will result in a delay of your shipment.
6. Uni-Source Office Furniture Parts, Inc. does not warrant COM textiles. COM textiles are tested for application only; they are not tested for performance.
7. Suppliers of COM textiles are responsible for color consistency within commercial tolerances, UV stability, and resistance to soiling and perspiration.

### CUSTOMER'S OWN MATERIAL PRICING

8. There may be additional application charges for COM fabrics. Please contact Customer Service for information.
  9. Ordering, shipping and payment of COM textile yardage are the responsibility of the customer and the textile supplier.
- 

### Acknowledgments

It is the purchaser's responsibility to check the acknowledgment document for accuracy, correct fabric and finish selections, etc. on all orders. It is also the purchaser's responsibility to immediately notify UniSource Office Furniture Parts, Inc. in writing of any problems or modifications needed to the acknowledge products. Once production has begun the product acknowledgement will become the order and any problems may result in specific costs to the purchaser.

### Deductions

Deductions from invoices are not allowed for any reason without written authorization from UniSource Office Furniture Parts, Inc. All requests for deductions must be made in writing within 30 days of receipt of the product. After 30 days no deductions will be allow. A written acceptance of the deduction if approved will be sent to the purchaser by UniSource Office Furniture Parts, Inc.. The purchaser must provide written proof of acceptance in writing by UniSource Office Furniture Parts, Inc. prior to taking deductions on the bill.

### Local Codes

UniSource Office Furniture Parts, Inc. considers its product to be office furniture and subject to all applicable local fire, electrical and building codes. SINCE LOCAL CODES VARY, THE PURCHASER IS RESPONSIBLE FOR THE PROPER APPLICATION AND INSTALLATION OF UNISOURCE OFFICE FURNITURE PARTS, INC.'S PRODUCT IN ACCORDANCE WITH THE REQUIREMENTS OF THESE LOCAL CODES. Engineering, research and testing have been conducted to have electrical components of UniSource Office Furniture Parts, Inc.'s products conform to national electrical codes. Only Underwriters Laboratories tested and approved electrical components of Uni-Source Office Furniture Parts, Inc.'s products conform to national electrical devices. In addition, some panels and components used by UniSource Office Furniture Parts, Inc. have been UL listed. UniSource Office Furniture Parts, Inc. shall not be responsible for any damages or expenses resulting from Purchaser's specifications not conforming to the requirements of the law or local building codes, unless it specifically agrees in writing to do so.

Since UniSource Office Furniture Parts, Inc. has no control over the use to which others may put its products, each user, dealer or specifier should determine the products suitability for the particular application and local, state or national codes for their application.

# MIRAGE INDEX

<b>MIRAGE PRODUCT</b>	<b>PAGE</b>
<b><u>TRIMS, FABRICS AND LAMINATES</u></b>	5-6
<b><u>MIRAGE A2 PRODUCT</u></b>	
A2 PANELS2	7-27
A2 CONNECTORS AND WALL MOUNTS	29-31
A2 ENERGY COMPONENTS	33-35
A2 WORK SURFACES	37-44
A2 TABLES	45
A2 OVERHEAD STORAGE	46-50
A2 TACKBOARDS	51
<b><u>MIRAGE A1 PRODUCT</u></b>	
A1 PANELS	53-61
A1 PANEL CONNECTORS	63-65
<b><u>MIRAGE CORRESPONDING PRODUCT</u></b>	
PEDESTALS	67 - 68
STORAGE CABINETS, STORAGE TOWERS	69
BOOKCASES, WARDROBE CABINETS	70
LATERAL FILES	71
TASKLIGHTS	72
CORD MANAGER	72
PAPER MANAGEMENT	72
PENCIL DRAWER	73
COMPUTER ACCESSORIES	73
MARKER BOARDS	74
DATA/VOICE COVERS & JACKS	74



All Finishes on these two pages apply exclusively to the Mirage Product, the finishes for other products are listed in the specific price pages for those products. These finishes are not available on all items please see the specific item page for details and applications.

**FINISH AND TRIM MATRIX FOR MIRAGE PRODUCTS ONLY**

X-Must Specify  
 O-Optional  
 - Not Applicable

Component	Fabrics	Paint Trim	Raceway Trim	Laminates	Edge Band Trim	OPTIONAL
<b>Panels</b>						
Panel Trim	X	-	-	-	-	-
Panel Raceway	-	X	-	-	-	-
<b>Connectors</b>						
Connector Trim	-	X	-	-	-	-
Connector Raceway	-	-	X	-	-	-
<b>Electrical</b>						
Receptacles	-	-	Black Only	-	-	-
Pass Through	-	-	-	-	-	-
Power Entry	-	-	-	-	-	X-RH/LH
Power Poles	-	X-Lmtd Colors	-	-	-	-
<b>Worksurfaces</b>						
Brackets	-	X	-	-	-	-
Legs	-	X	-	-	-	-
Top Only	-	-	-	X	X	-
WS With hardware	-	X	-	X	X	-
Tables with bases	-	X	-	X	X	-
Table Tops Only	-	-	-	X	X	-
<b>Storage</b>						
Shelves Open	-	X	-	-	-	-
Flipper Door Units	X	X	-	-	-	-
Flipper Door	X	X	-	-	-	-
Metal Flipper Units	-	X	-	-	-	-
<b>Tackboards</b>						
	X	-	-	-	-	-
<b>Pedestals/Files</b>						
	-	X	-	-	-	-
<b>Accessories</b>						
	-	Black Only	-	-	-	-

**Available Paint Finishes:**

Color Code:	Color:	Availability
BU	Black Umber	All Items shown above
DT	Dark Tone	Limited items see individual products, Note Product can have upcharges, see individual items
HT	Innertone	Limited items see individual products
LG	Light Grey	All Items shown above
LT	Light Tone	All Items shown above
MT	Medium Tone	All Items shown above

**Available Raceway Trim Finishes:**

Color Code:	Color:	Availability
B	Black Umber	All Raceway Trim on A2 Panels, not available on A1 Panels
D	Dark Tone	All Raceway Trim on A2 Panels, not available on A1 Panels, Note \$25 per panel upcharge
M	Medium Tone	All Raceway Trim on A2 Panels, not available on A1 Panels

**Available Work Surface Edge Band Finishes:**

Color Code:	Color:	Availability
BU	Black Umber	A1 T Edge and A2 3mm Edge
DT	Dark Tone	A1 T Edge and A2 3mm Edge
HT	Innertone	A1 T Edge and A2 3mm Edge
LG	Light Grey	A1 T Edge and A2 3mm Edge
LT	Light Tone	A1 T Edge and A2 3mm Edge
MT	Medium Tone	A1 T Edge and A2 3mm Edge

**FABRIC GRADES AND AVAILABILITY**

Prime Source



[www.cfstinson.com](http://www.cfstinson.com)

1-800-841-6279 M-F Eastern Time

All Prime source products are available in the grades shown. Sample cards are not included in the UniSource binders, and may be ordered through our prime source supplier CF Stinson 1-800-841-6279 or on-line at [www.cfstinson.com](http://www.cfstinson.com)

NOTE: All Fabrics on Mirage are applied Railroaded, unless otherwise specified or 80/85 high products are used.

Please contact Customer Service at 1-800-598-7278 for information

Regarding COM Fabrics or specific fabric appearance due to direction. COM Fabrics are priced as Grade Q and are subject to approval, as not all fabrics will work, fabrics less than 66" w are subject to rejection. Please contact Customer Service for additional assistance.

Fabrics must be panel grade, vertically stable fabrics.COM Fabrics do not have a warranty.

Patterns Available All Colors	Grade Q	Grade 1	Grade 2	Grade 3	Grade 4
	Advantage	Axis Too	Acclaim	Asterisk	Celebration
	Prime	Genesis	Budget Blends	Brush Style	Linea
	VS	Reflectance	Counterpoint	Dividend	Lumiere
			Crossweave	Galaxy	Lupina
			Crystal	Isis	Raffioso
			Del Mar	Luther II	Shoji
			Encore	Mordezza	Tally
			Mira	Prism	
			Razzle	Roundabout	
			Repetition	Sightline	
			Ringer	Spiro & Rev	
			Surface	Terrain	
			Traffic	Vertical Blends	

**PLEASE NOTE:** If you have a critical time shipment, please contact customer service with the specific color, pattern and pattern number to check current availability at time of order.

**LAMINATE, STANDARD OFFERINGS**

**High Pressure Laminate-3mm Edge and T Edge Only**

\*\*Note: Available on A2 3mm PVC and A1 T Edge tops only. You must Specify the Edge Band T Edge and 3mm Edge Band Options: BU, DT, HF, HT, LG, LT, MT

Featuring Wilsonart Laminates. All pricing is for STANDARD PRICING GRADES ONLY. Additional patterns are available. Contact customer service for pricing and availability. If you have a project that is time sensitive, please contact customer service to verify availability.

Solid Colors:	1503-60	Putty	D391-60	Cloud	D96-60	Shadow
	D30-60	Natural Almond	D337-60	Pebble	D91-60	Slate Grey
	D315-60	Platinum	D72-60	Featherstone	D327-60	Pepperdust
	D439-60	Wallaby				

\*\*\*\*\*All other "The Standard" Line Solid Wilsonart Patterns see [www.wilsonart.com](http://www.wilsonart.com), Standard pricing grade and finish coating -60 only

Patterns:	4608-60	Caldera Beige	4142-60	Grey Glace	4667-60	Green Tigris
	4633-60	Natural Nebula	4621-60	White Nebula	4674-60	Evening Tigris
	4630-60	Cloud Nebula	4166-60	Pampas	4622-60	Grey Nebula

\*\*\*\*\*All other "The Standard" Line Solid Wilsonart Patterns see [www.wilsonart.com](http://www.wilsonart.com), Standard pricing grade and finish coating -60 only

Woodgrains:	7054-60	Wild Cherry	7061-60	Natural Pear	7908-60	Sanibel Maple
	7039-60	Windsor Mahogany	7888-60	Golden Oak	7290-60	Nepal Teak
	7919-60	Amber Cherry	7040A-60	Figured Mahogany	10776-60	Kennington Maple
	7909-60	Fusion Maple	7885T-60	English Oak		
	7911-60	Manitoba Maple	7110T-60	Montana Walnut		

\*\*\*\*\*All other "The Standard" Line Solid Wilsonart Patterns see [www.wilsonart.com](http://www.wilsonart.com), Standard pricing grade and finish coating -60 only

## A2 NONPOWERED FABRIC PANEL

### Product Description

Fabric covered hard surface panel with nonpowered wire management attached. Includes (1) panel, (2) base covers & (1) metal base attached.

**PANEL CONNECTORS MUST BE ORDERED SEPARATELY.**

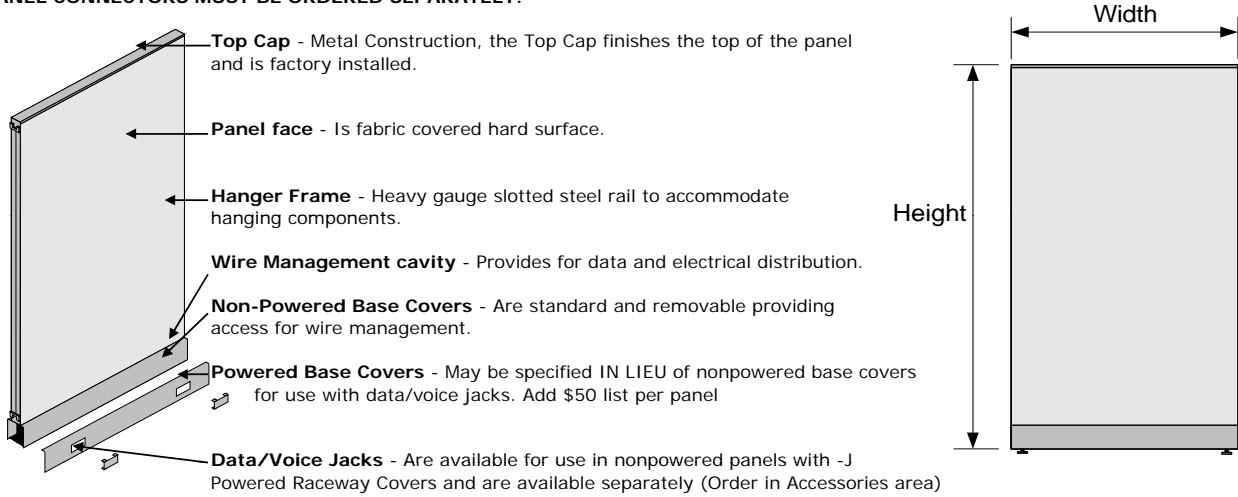

### Actual Dimensions

Depth (Thickness)	2" at top, 3 1/2" at raceway
Width	12", 18", 24", 30", 36", 42", 48" & 60"
Height (Minimum)	39", 47", 53", 62", 67" & 85"
Wire Management	5"

### Specify:

- \* Product number.
- \* Wire Management color – "X" (B=BU,D=DT add +\$25 per panel, M=MT)
- \* Wire Management Option, Raceway with Power Openings and 2 outlets per Add +\$50 per panel -J
- \* Trim color – "YY" (BU, DT, HT, LG, LT, MT)

### Note:

- \* Order Finished End (Pg. 31) to finish exposed panel end.
- \* Order Panel Connectors (Pgs. 30-31 ) separately.
- \* Fabric yardage estimate is for directional application (minimum 66"width).
- \* Special fabrics may affect yardage requirements.

DIMENSION: H x W	ITEM NUMBER	FABRIC Q COM LIST	FABRIC GRADE 1 LIST	FABRIC GRADE 2 LIST	FABRIC GRADE 3 LIST	FABRIC GRADE 4 LIST	YDG REQ'D	WEIGHT
39 x 12	HENX.3912YY	\$317	\$351	\$386	\$420	\$442	1.25	16
39 x 18	HENX.3918YY	\$336	\$370	\$404	\$439	\$460	1.25	21
39 x 24	HENX.3924YY	\$344	\$378	\$412	\$447	\$470	1.25	22
39 x 30	HENX.3930YY	\$381	\$414	\$476	\$538	\$565	2.25	23
39 x 36	HENX.3936YY	\$436	\$468	\$529	\$592	\$621	2.25	28
39 x 42	HENX.3942YY	\$464	\$494	\$556	\$618	\$649	2.25	31
39 x 48	HENX.3948YY	\$488	\$518	\$581	\$643	\$675	2.25	33
39 x 60	HENX.3960YY	\$618	\$645	\$708	\$769	\$808	2.25	39

## A2 NONPOWERED FABRIC PANEL

**Specify:**

- \* Product number.
- \* Wire Management color – "X" (B=BU,D=DT add +\$25 per panel, M=MT)
- \* Wire Managementt Option, Raceway with Power Openings and 2 outlets per Add +\$50 per panel -J
- \* Trim color – "YY" (BU, DT, HT, LG, LT, MT)

**Note:**

- \* Order Finished End (Pg. 31) to finish exposed panel end.
- \* Order Panel Connectors (Pgs. 30-31) separately.
- \* Fabric yardage estimate is for directional application (min 66" width).
- \* Special fabrics may affect yardage requirements.

DIMENSION: H x W	ITEM NUMBER	FABRIC Q COM LIST	FABRIC GRADE 1 LIST	FABRIC GRADE 2 LIST	FABRIC GRADE 3 LIST	FABRIC GRADE 4 LIST	YDG REQ'D	WEIGHT
47 x 12	HENX.4712YY	\$328	\$373	\$390	\$447	\$469	1.34	20
47 x 18	HENX.4718YY	\$346	\$390	\$447	\$465	\$488	1.34	24
47 x 24	HENX.4724YY	\$381	\$427	\$457	\$475	\$499	1.34	25
47 x 30	HENX.4730YY	\$437	\$480	\$559	\$596	\$626	2.67	28
47 x 36	HENX.4736YY	\$504	\$546	\$642	\$661	\$694	2.67	32
47 x 42	HENX.4742YY	\$531	\$572	\$683	\$719	\$755	2.67	34
47 x 48	HENX.4748YY	\$548	\$587	\$727	\$734	\$771	2.67	37
47 x 60	HENX.4760YY	\$689	\$725	\$889	\$872	\$917	2.67	42
53 x 12	HENX.5312YY	\$338	\$382	\$391	\$465	\$488	1.50	22
53 x 18	HENX.5318YY	\$346	\$402	\$452	\$484	\$508	1.50	26
53 x 24	HENX.5324YY	\$376	\$410	\$461	\$492	\$517	1.50	27
53 x 30	HENX.5330YY	\$434	\$467	\$569	\$632	\$664	3.00	31
53 x 36	HENX.5336YY	\$507	\$557	\$651	\$723	\$759	3.00	36
53 x 42	HENX.5342YY	\$540	\$590	\$691	\$756	\$793	3.00	40
53 x 48	HENX.5348YY	\$581	\$630	\$735	\$796	\$835	3.00	43
53 x 60	HENX.5360YY	\$731	\$777	\$897	\$942	\$990	3.00	50
62 x 12	HENX.6212YY	\$351	\$376	\$423	\$486	\$511	2.00	24
62 x 18	HENX.6218YY	\$411	\$465	\$512	\$575	\$604	2.00	30
62 x 24	HENX.6224YY	\$453	\$495	\$520	\$585	\$615	2.00	32
62 x 30	HENX.6230YY	\$482	\$534	\$649	\$735	\$773	3.67	35
62 x 36	HENX.6236YY	\$569	\$618	\$745	\$820	\$861	3.67	41
62 x 42	HENX.6242YY	\$612	\$660	\$790	\$862	\$905	3.67	45
62 x 48	HENX.6248YY	\$658	\$706	\$838	\$907	\$953	3.67	50
62 x 60	HENX.6260YY	\$828	\$871	\$960	\$1,073	\$1,127	3.67	59
67 x 12	HENX.6712YY	\$353	\$408	\$462	\$518	\$544	2.00	24
67 x 18	HENX.6718YY	\$416	\$470	\$525	\$580	\$609	2.00	30
67 x 24	HENX.6724YY	\$457	\$500	\$535	\$590	\$619	2.00	32
67 x 30	HENX.6730YY	\$487	\$539	\$644	\$748	\$786	3.80	35
67 x 36	HENX.6736YY	\$574	\$623	\$728	\$832	\$874	3.80	41
67 x 42	HENX.6742YY	\$616	\$664	\$769	\$873	\$918	3.80	45
67 x 48	HENX.6748YY	\$662	\$710	\$815	\$919	\$965	3.80	50
67 x 60	HENX.6760YY	\$832	\$876	\$981	\$1,085	\$1,139	3.80	59
85 x 12	HENX.8512YY	\$376	\$469	\$535	\$602	\$631	2.40	34
85 x 18	HENX.8518YY	\$469	\$559	\$626	\$692	\$726	2.40	42
85 x 24	HENX.8524YY	\$477	\$568	\$634	\$700	\$735	2.40	44
85 x 30	HENX.8530YY	\$542	\$631	\$764	\$896	\$941	4.80	50
85 x 36	HENX.8536YY	\$643	\$729	\$862	\$995	\$1,044	4.80	55
85 x 42	HENX.8542YY	\$690	\$776	\$908	\$1,041	\$1,093	4.80	60
85 x 48	HENX.8548YY	\$742	\$826	\$958	\$1,091	\$1,145	4.80	64
85 x 60	HENX.8560YY	\$869	\$951	\$1,083	\$1,215	\$1,276	4.80	74

## A2 POWERED FABRIC PANEL

### Product Description

Fabric covered hard surface panel with powered wire management attached. Includes (1) panel, (2) base covers, (2) outlet covers, (1) metal base attached & (1) electrical harness. Duplex receptacles and additional outlet covers must be ordered separately.

**PANEL CONNECTORS MUST BE ORDERED SEPARATELY.**

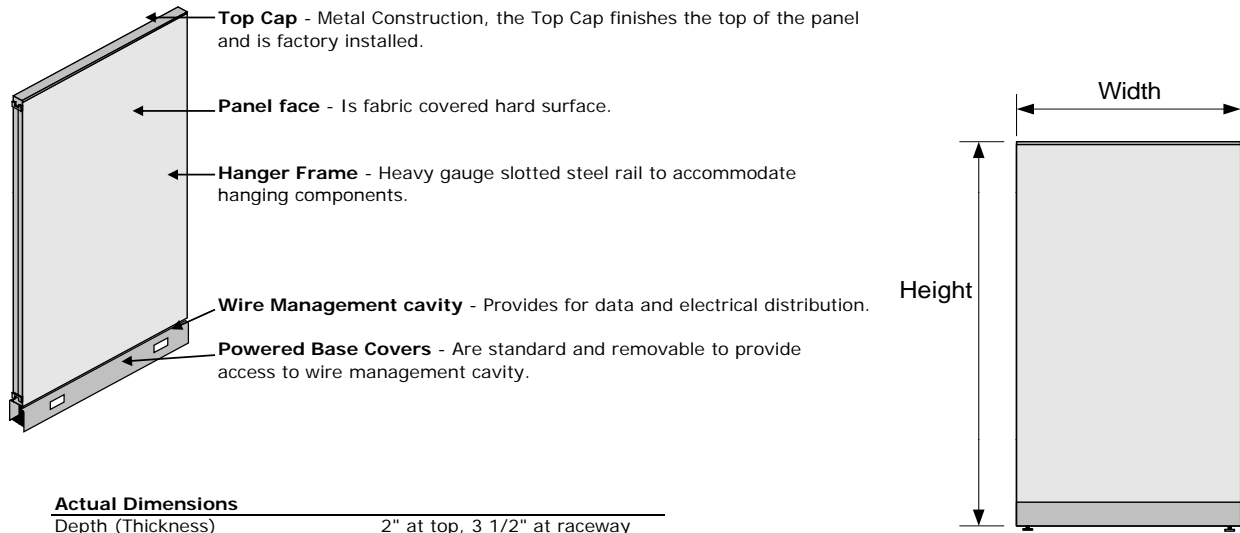

### Actual Dimensions

Depth (Thickness)	2" at top, 3 1/2" at raceway
Width	24", 30", 36", 42", 48" & 60"
Height (Minimum)	39", 47", 53", 62", 67" & 85"
Wire Management	5"

## A2 POWERED FABRIC PANEL

### Specify:

- \* Product number.
- \* Wire Management color – "X" (B=BU,D=DT add +\$25 per panel, M=MT)
- \* Wire Management Option, Raceway with Power Openings and 2 outlets per Add +\$50 per panel -J
- \* Trim color – "YY" (BU, DT, HT, LG, LT, MT)

### Note:

- \* Includes Electrical Harness.
- \* Order Finished End (Pg. 31) to finish exposed panel end.
- \* Order Panel Connectors (Pgs. 30-31) and Festoons (Pg. 34) separately.
- \* Fabric yardage estimate is for directional application (min 66" width).
- \* Special fabrics may affect yardage requirements.

DIMENSION: H x W	ITEM NUMBER	FABRIC Q COM LIST	FABRIC GRADE 1 LIST	FABRIC GRADE 2 LIST	FABRIC GRADE 3 LIST	FABRIC GRADE 4 LIST	YDG REQ'D	WEIGHT
39 x 24	HEPX.3924YY	\$518	\$536	\$570	\$605	\$634	1.25	25
39 x 30	HEPX.3930YY	\$556	\$572	\$633	\$695	\$730	2.25	26
39 x 36	HEPX.3936YY	\$611	\$624	\$686	\$748	\$786	2.25	31
39 x 42	HEPX.3942YY	\$640	\$651	\$714	\$776	\$815	2.25	34
39 x 48	HEPX.3948YY	\$666	\$677	\$739	\$801	\$842	2.25	36
39 x 60	HEPX.3960YY	\$797	\$801	\$863	\$926	\$972	2.25	42
47 x 24	HEPX.4724YY	\$531	\$558	\$595	\$632	\$664	1.34	28
47 x 30	HEPX.4730YY	\$581	\$606	\$680	\$753	\$791	2.67	31
47 x 36	HEPX.4736YY	\$649	\$671	\$744	\$818	\$859	2.67	35
47 x 42	HEPX.4742YY	\$709	\$727	\$801	\$874	\$919	2.67	37
47 x 48	HEPX.4748YY	\$727	\$746	\$819	\$893	\$937	2.67	40
47 x 60	HEPX.4760YY	\$873	\$884	\$957	\$1,031	\$1,083	2.67	45
53 x 24	HEPX.5324YY	\$551	\$567	\$609	\$650	\$682	1.50	30
53 x 30	HEPX.5330YY	\$588	\$623	\$706	\$789	\$828	3.00	34
53 x 36	HEPX.5336YY	\$674	\$705	\$787	\$869	\$914	3.00	39
53 x 42	HEPX.5342YY	\$719	\$748	\$830	\$914	\$959	3.00	43
53 x 48	HEPX.5348YY	\$761	\$788	\$870	\$953	\$1,001	3.00	46
53 x 60	HEPX.5360YY	\$914	\$933	\$1,017	\$1,099	\$1,154	3.00	53
62 x 24	HEPX.6224YY	\$577	\$613	\$667	\$723	\$759	2.00	35
62 x 30	HEPX.6230YY	\$632	\$665	\$766	\$867	\$912	3.67	38
62 x 36	HEPX.6236YY	\$721	\$750	\$851	\$952	\$1,000	3.67	44
62 x 42	HEPX.6242YY	\$783	\$809	\$911	\$1,011	\$1,062	3.67	48
62 x 48	HEPX.6248YY	\$821	\$845	\$946	\$1,048	\$1,100	3.67	53
62 x 60	HEPX.6260YY	\$987	\$1,003	\$1,104	\$1,205	\$1,266	3.67	62
67 x 24	HEPX.6724YY	\$602	\$636	\$691	\$746	\$783	2.00	35
67 x 30	HEPX.6730YY	\$662	\$693	\$798	\$903	\$949	3.80	38
67 x 36	HEPX.6736YY	\$753	\$780	\$885	\$990	\$1,039	3.80	44
67 x 42	HEPX.6742YY	\$797	\$822	\$927	\$1,032	\$1,084	3.80	48
67 x 48	HEPX.6748YY	\$843	\$866	\$970	\$1,075	\$1,129	3.80	53
67 x 60	HEPX.6760YY	\$1,020	\$1,033	\$1,138	\$1,243	\$1,306	3.80	62
85 x 24	HEPX.8524YY	\$653	\$724	\$790	\$857	\$899	2.40	47
85 x 30	HEPX.8530YY	\$720	\$788	\$920	\$1,053	\$1,105	4.80	53
85 x 36	HEPX.8536YY	\$784	\$824	\$1,020	\$1,152	\$1,209	4.80	58
85 x 42	HEPX.8542YY	\$873	\$933	\$1,066	\$1,198	\$1,259	4.80	63
85 x 48	HEPX.8548YY	\$925	\$983	\$1,115	\$1,248	\$1,310	4.80	67
85 x 60	HEPX.8560YY	\$1,057	\$1,108	\$1,241	\$1,374	\$1,442	4.80	771

## A2 NONPOWERED FABRIC ACOUSTICAL PANEL

### Product Description

Fabric covered sound-reducing panel with nonpowered wire management attached. Includes (1) panel, (2) base covers & (1) metal base attached.

**PANEL CONNECTORS MUST BE ORDERED SEPARATELY.**

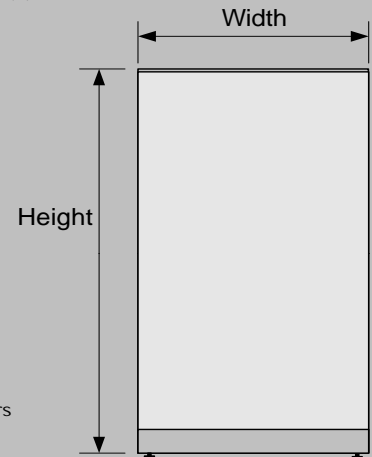
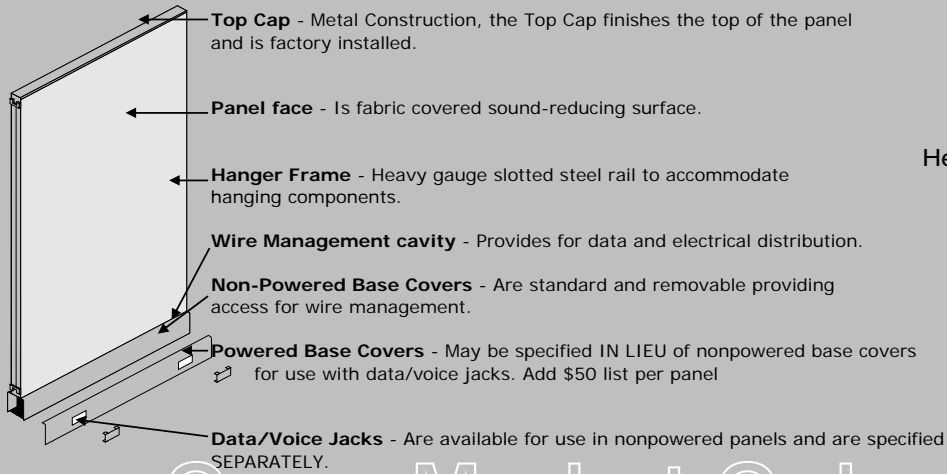

### Actual Dimensions

Depth (Thickness)	2" at top, 3 1/2" at base
Width	12", 18", 24", 30", 36", 42", 48" & 60"
Height (Minimum)	53", 52", 67" & 85"
Wire Management	5"

### Specify:

- \* Product number.
- \* Wire Management color - "X" (B=BU,D=DT add +\$25 per panel, M=MT)
- \* Wire Management Option, Raceway with Power Openings and 2 outlets per Add +\$50 per panel -J
- \* Trim color - "YY" (BU, DT, HT, LG, LT, MT)

### Note:

- \* Order Finished End (Pg. 31) to finish exposed panel end.
- \* Order Panel Connectors (Pgs. 30-31) separately.
- \* Fabric yardage estimate is for directional application (min 66" width).
- \* Special fabrics may affect yardage requirements. 1

## A2 NONPOWERED FABRIC ACOUSTICAL PANEL

### Specify:

- \* Product number.
- \* Wire Management color – "X" (B=BU,D=DT add +\$25 per panel, M=MT)
- \* Wire Management Option, Raceway with Power Openings and 2 outlets per Add +\$50 per panel -J
- \* Trim color – "YY" (BU, DT, HT, LG, LT, MT)

### Note:

- \* Order Finished End (Pg. 31) to finish exposed panel end.
- \* Order Panel Connectors (Pgs. 30-31) separately.
- \* Fabric yardage estimate is for directional application (min 66" width).
- \* Special fabrics may affect yardage requirements.

DIMENSION: H x W	ITEM NUMBER	FABRIC Q COM LIST	FABRIC GRADE 1 LIST	FABRIC GRADE 2 LIST	FABRIC GRADE 3 LIST	FABRIC GRADE 4 LIST	YDG REQ'D	WEIGHT
53 x 12	HEANX.5312YY	\$448	\$492	\$534	\$575	\$604	1.50	25
53 x 18	HEANX.5318YY	\$507	\$548	\$589	\$630	\$662	1.50	29
53 x 24	HEANX.5324YY	\$514	\$555	\$596	\$639	\$671	1.50	30
53 x 30	HEANX.5330YY	\$567	\$605	\$688	\$770	\$810	3.00	34
53 x 36	HEANX.5336YY	\$641	\$676	\$758	\$842	\$884	3.00	39
53 x 42	HEANX.5342YY	\$677	\$711	\$793	\$877	\$920	3.00	43
53 x 48	HEANX.5348YY	\$716	\$749	\$831	\$915	\$960	3.00	46
53 x 60	HEANX.5360YY	\$893	\$918	\$1,000	\$1,084	\$1,137	3.00	53
62 x 12	HEANX.6212YY	\$474	\$516	\$571	\$626	\$658	2.00	27
62 x 18	HEANX.6218YY	\$519	\$559	\$615	\$670	\$703	2.00	33
62 x 24	HEANX.6224YY	\$529	\$571	\$625	\$681	\$715	2.00	35
62 x 30	HEANX.6230YY	\$576	\$615	\$716	\$817	\$858	3.67	38
62 x 36	HEANX.6236YY	\$662	\$697	\$798	\$899	\$945	3.67	44
62 x 42	HEANX.6242YY	\$693	\$726	\$828	\$929	\$975	3.67	48
62 x 48	HEANX.6248YY	\$734	\$765	\$867	\$968	\$1,017	3.67	53
62 x 60	HEANX.6260YY	\$905	\$929	\$1,030	\$1,132	\$1,189	3.67	62
67 x 12	HEANX.6712YY	\$483	\$525	\$581	\$637	\$668	2.00	27
67 x 18	HEANX.6718YY	\$529	\$571	\$625	\$681	\$715	2.00	33
67 x 24	HEANX.6724YY	\$540	\$580	\$635	\$690	\$724	2.00	35
67 x 30	HEANX.6730YY	\$592	\$630	\$735	\$840	\$882	3.80	38
67 x 36	HEANX.6736YY	\$672	\$706	\$810	\$915	\$961	3.80	44
67 x 42	HEANX.6742YY	\$703	\$735	\$841	\$946	\$993	3.80	48
67 x 48	HEANX.6748YY	\$750	\$780	\$885	\$990	\$1,039	3.80	53
67 x 60	HEANX.6760YY	\$916	\$939	\$1,045	\$1,149	\$1,207	3.80	62
85 x 12	HEANX.8512YY	\$526	\$606	\$672	\$739	\$776	2.40	37
85 x 18	HEANX.8518YY	\$587	\$664	\$730	\$796	\$836	2.40	45
85 x 24	HEANX.8524YY	\$594	\$671	\$737	\$803	\$843	2.40	47
85 x 30	HEANX.8530YY	\$650	\$724	\$857	\$989	\$1,038	4.80	53
85 x 36	HEANX.8536YY	\$751	\$820	\$953	\$1,086	\$1,139	4.80	58
85 x 42	HEANX.8542YY	\$796	\$863	\$996	\$1,129	\$1,186	4.80	63
85 x 48	HEANX.8548YY	\$857	\$922	\$1,054	\$1,187	\$1,246	4.80	67
85 x 60	HEANX.8560YY	\$992	\$1,052	\$1,184	\$1,316	\$1,382	4.80	771

## A2 POWERED FABRIC ACOUSTICAL PANEL

### Product Description

Fabric covered sound-reducing panel with powered wire management attached. Includes (1) panel, (2) base covers, (2) outlet covers, (1) metal base attached & (1) electrical harness. Duplex receptacles and additional outlet covers must be ordered separately.

### PANEL CONNECTORS MUST BE ORDERED SEPARATELY.

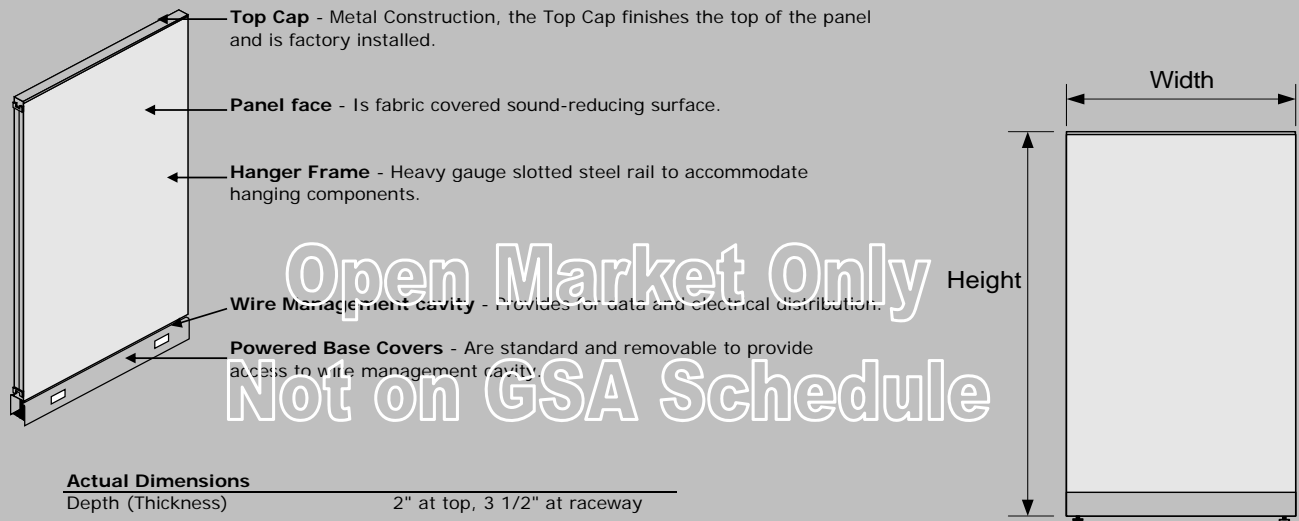

### Actual Dimensions

Depth (Thickness)	2" at top, 3 1/2" at raceway
Width	24", 30", 36", 42", 48" & 60"
Height (Minimum)	53", 62", 67" & 85"
Wire Management	5"

### Specify:

- \* Product number.
- \* Wire Management color - "X" (B=BU,D=DT add +\$25 per panel, M=MT)
- \* Wire Management Option, Raceway with Power Openings and 2 outlets per Add +\$50 per panel - J
- \* Trim color - "YY" (BU, DT, HT, LG, LT, MT)1

## A2 POWERED FABRIC ACOUSTICAL PANEL

**Specify:**

- \* Product number.
- \* Wire Management color – "X" (B=BU,D=DT add +\$25 per panel, M=MT)
- \* Wire Management Option, Raceway with Power Openings and 2 outlets per Add +\$50 per panel -J
- \* Trim color – "YY" (BU, DT, HT, LG, LT, MT)

**Note:**

- \* Includes Electrical Harness.
- \* Order Finished End (Pg. 31) to finish exposed panel end.
- \* Order Panel Connectors (Pgs. 30-31) and Festoons (Pg. 34) separately.
- \* Fabric yardage estimate is for directional application (min 66" width).
- \* Special fabrics may affect yardage requirements.

DIMENSION: H x W	ITEM NUMBER	FABRIC Q COM LIST	FABRIC GRADE 1 LIST	FABRIC GRADE 2 LIST	FABRIC GRADE 3 LIST	FABRIC GRADE 4 LIST	YDG REQ'D	WEIGHT
53 x 24	HEAPX.5324YY	\$666	\$714	\$755	\$796	\$836	1.50	33
53 x 30	HEAPX.5330YY	\$715	\$761	\$844	\$927	\$973	3.00	37
53 x 36	HEAPX.5336YY	\$788	\$832	\$915	\$998	\$1,048	3.00	42
53 x 42	HEAPX.5342YY	\$825	\$868	\$951	\$1,033	\$1,086	3.00	46
53 x 48	HEAPX.5348YY	\$863	\$905	\$989	\$1,071	\$1,125	3.00	49
53 x 60	HEAPX.5360YY	\$1,038	\$1,075	\$1,159	\$1,241	\$1,304	3.00	56
62 x 24	HEAPX.6224YY	\$684	\$730	\$786	\$842	\$883	2.00	38
62 x 30	HEAPX.6230YY	\$735	\$782	\$863	\$944	\$1,033	3.67	41
62 x 36	HEAPX.6236YY	\$812	\$855	\$957	\$1,058	\$1,110	3.67	47
62 x 42	HEAPX.6242YY	\$844	\$887	\$988	\$1,090	\$1,144	3.67	51
62 x 48	HEAPX.6248YY	\$883	\$924	\$1,035	\$1,137	\$1,194	3.67	56
62 x 60	HEAPX.6260YY	\$1,050	\$1,088	\$1,199	\$1,290	\$1,354	3.67	65
67 x 24	HEAPX.6724YY	\$690	\$736	\$792	\$848	\$890	2.00	38
67 x 30	HEAPX.6730YY	\$742	\$787	\$891	\$996	\$1,046	3.80	41
67 x 36	HEAPX.6736YY	\$818	\$861	\$966	\$1,071	\$1,125	3.80	47
67 x 42	HEAPX.6742YY	\$852	\$894	\$999	\$1,104	\$1,159	3.80	51
67 x 48	HEAPX.6748YY	\$896	\$937	\$1,042	\$1,147	\$1,205	3.80	56
67 x 60	HEAPX.6760YY	\$1,060	\$1,097	\$1,202	\$1,307	\$1,372	3.80	65
85 x 24	HEAPX.8524YY	\$744	\$828	\$894	\$960	\$1,008	2.40	50
85 x 30	HEAPX.8530YY	\$798	\$882	\$1,015	\$1,146	\$1,204	4.80	56
85 x 36	HEAPX.8536YY	\$900	\$981	\$1,113	\$1,246	\$1,308	4.80	61
85 x 42	HEAPX.8542YY	\$941	\$1,021	\$1,154	\$1,285	\$1,350	4.80	66
85 x 48	HEAPX.8548YY	\$1,000	\$1,078	\$1,210	\$1,343	\$1,410	4.80	70
85 x 60	HEAPX.8560YY	\$1,124	\$1,198	\$1,331	\$1,464	\$1,537	4.80	80

## A2 NONPOWERED FABRIC TACKABLE ACOUSTICAL PANEL

### Product Description

Fabric covered tackable sound-reducing panel with nonpowered wire management attached. Includes (1) panel, (2) base covers & (1) metal base attached.

**PANEL CONNECTORS MUST BE ORDERED SEPARATELY.**

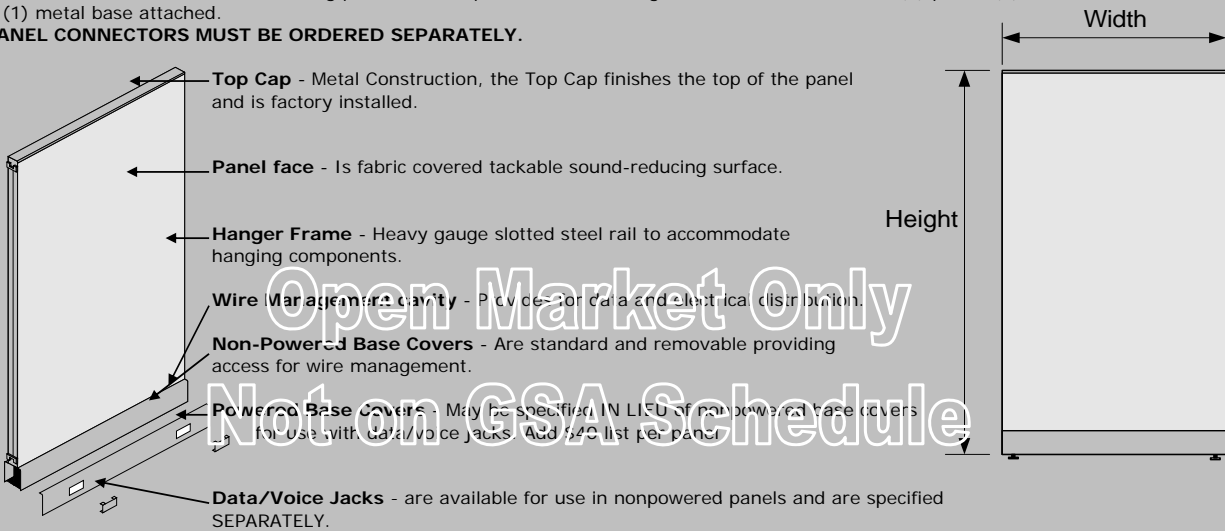

### Actual Dimensions

Depth (Thickness)	2" at top, 3 3/8" at base
Width	12", 18", 24", 30", 36", 42", 48" & 60"
Height (Minimum)	53", 62", 67" & 85"
Wire Management	5"

### Specify:

- \* Product number.
- \* Wire Management color - "X" (B=BU,D=DT add +\$25 per panel, M=MT)
- \* Wire Management Option, Raceway with Power Openings and 2 outlets per Add +\$50 per panel -J
- \* Trim color - "YY" (BU, DT, HT, LG, LT, MT)

### Note:

- \* Order Finished End (Pg. 31) to finish exposed panel end.
- \* Order Panel Connectors (Pgs. 30-31) separately.
- \* Fabric yardage estimate is for directional application (min 66" width).
- \* Special fabrics may affect yardage requirements.

## A2 NONPOWERED FABRIC TACKABLE ACOUSTICAL PANEL

**Specify:**

- \* Product number.
- \* Wire Management color – "X" (B=BU,D=DT add +\$25 per panel, M=MT)
- \* Wire Management Option, Raceway with Power Openings and 2 outlets per Add +\$50 per panel -J
- \* Trim color – "YY" (BU, DT, HT, LG, LT, MT)

**Note:**

- \* Order Finished End (Pg. 31) to finish exposed panel end.
- \* Order Panel Connectors (Pgs. 30-31) separately.
- \* Fabric yardage estimate is for directional application (min 66" width).
- \* Special fabrics may affect yardage requirements.

DIMENSION: H x W	ITEM NUMBER	FABRIC Q COM LIST	FABRIC GRADE 1 LIST	FABRIC GRADE 2 LIST	FABRIC GRADE 3 LIST	FABRIC GRADE 4 LIST	YDG REQ'D	WEIGHT
53 x 12	HETNX.5312YY	\$456	\$481	\$523	\$564	\$592	1.50	31
53 x 18	HETNX.5318YY	\$480	\$519	\$561	\$603	\$632	1.50	35
53 x 24	HETNX.5324YY	\$506	\$560	\$602	\$644	\$676	1.50	36
53 x 30	HETNX.5330YY	\$539	\$607	\$690	\$773	\$812	3.00	40
53 x 36	HETNX.5336YY	\$562	\$645	\$728	\$811	\$851	3.00	45
53 x 42	HETNX.5342YY	\$584	\$681	\$764	\$847	\$889	3.00	49
53 x 48	HETNX.5348YY	\$621	\$732	\$816	\$898	\$943	3.00	52
53 x 48	HETNX.5360YY	\$682	\$822	\$905	\$988	\$1,037	3.00	59
62 x 12	HETNX.6212YY	\$492	\$513	\$572	\$626	\$658	2.00	33
62 x 18	HETNX.6218YY	\$520	\$553	\$614	\$668	\$702	2.00	39
62 x 24	HETNX.6224YY	\$550	\$603	\$658	\$713	\$749	2.00	41
62 x 30	HETNX.6230YY	\$586	\$652	\$754	\$855	\$898	3.67	44
62 x 36	HETNX.6236YY	\$614	\$694	\$796	\$897	\$942	3.67	49
62 x 42	HETNX.6242YY	\$641	\$733	\$838	\$939	\$987	3.67	54
62 x 48	HETNX.6248YY	\$652	\$752	\$853	\$954	\$1,044	3.67	60
62 x 60	HETNX.6260YY	\$751	\$888	\$989	\$1,091	\$1,145	3.67	70
67 x 12	HETNX.6712YY	\$476	\$516	\$572	\$626	\$658	2.00	34
67 x 18	HETNX.6718YY	\$520	\$558	\$614	\$668	\$702	2.00	40
67 x 24	HETNX.6724YY	\$567	\$603	\$658	\$713	\$749	2.00	42
67 x 30	HETNX.6730YY	\$619	\$652	\$757	\$862	\$905	3.80	45
67 x 36	HETNX.6736YY	\$663	\$694	\$799	\$904	\$950	3.80	50
67 x 42	HETNX.6742YY	\$708	\$736	\$842	\$947	\$994	3.80	55
67 x 48	HETNX.6748YY	\$765	\$792	\$897	\$1,001	\$1,052	3.80	61
67 x 60	HETNX.6760YY	\$885	\$888	\$993	\$1,098	\$1,153	3.80	71
85 x 12	HETNX.8512YY	\$539	\$625	\$691	\$757	\$795	2.40	45
85 x 18	HETNX.8518YY	\$608	\$656	\$722	\$788	\$827	2.40	53
85 x 24	HETNX.8524YY	\$656	\$689	\$756	\$822	\$863	2.40	55
85 x 30	HETNX.8530YY	\$751	\$840	\$973	\$1,105	\$1,161	4.80	61
85 x 36	HETNX.8536YY	\$785	\$872	\$1,004	\$1,137	\$1,194	4.80	66
85 x 42	HETNX.8542YY	\$814	\$900	\$1,033	\$1,166	\$1,224	4.80	72
85 x 48	HETNX.8548YY	\$863	\$947	\$1,079	\$1,212	\$1,273	4.80	76
85 x 60	HETNX.8560YY	\$938	\$1,019	\$1,152	\$1,283	\$1,348	4.80	851

## A2 POWERED FABRIC TACKABLE ACOUSTICAL PANEL

### Product Description

Fabric covered tackable sound-reducing panel with powered wire management attached. Includes (1) panel, (2) base covers, (2) outlet covers, (1) metal base attached & (1) electrical harness. Duplex receptacles and additional outlet covers must be ordered separately.

### PANEL CONNECTORS MUST BE ORDERED SEPARATELY.

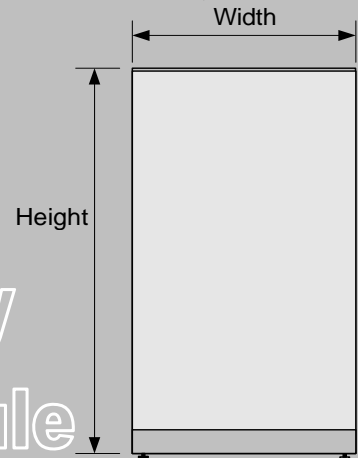

Open Market Only  
Not on GSA Schedule

### Actual Dimensions

Depth (Thickness)	2" at top, 3 3/8" at base
Width	24", 30", 36", 42", 48" & 60"
Height (Minimum)	53", 62", 67" & 85"
Wire Management	5"

### Specify:

- \* Product number.
- \* Wire Management color - "X" (B=BU,D=DT add +\$25 per panel, M=MT)
- \* Wire Management Option, Raceway with Power Openings and 2 outlets per Add +\$50 per panel -J
- \* Trim color - "YY" (BU, DT, HT, LG, LT, MT)1

## A2 POWERED FABRIC TACKABLE ACOUSTICAL PANEL

### Specify:

- \* Product number.
- \* Wire Management color – "X" (B=BU,D=DT add +\$25 per panel, M=MT)
- \* Wire Management Option, Raceway with Power Openings and 2 outlets per Add +\$50 per panel -J
- \* Trim color – "YY" (BU, DT, HT, LG, LT, MT)

### Note:

- \* Includes Electrical Harness.
- \* Order Finished End (Pg. 31) to finish exposed panel end.
- \* Order Panel Connectors (Pgs. 30-31) and Festoons (Pg. 34) separately.
- \* Fabric yardage estimate is for directional application (min 66" width).
- \* Special fabrics may affect yardage requirements.

DIMENSION: H x W	ITEM NUMBER	FABRIC Q COM LIST	FABRIC GRADE 1 LIST	FABRIC GRADE 2 LIST	FABRIC GRADE 3 LIST	FABRIC GRADE 4 LIST	YDG REQ'D	WEIGHT
53 x 24	HETPX.5324YY	\$603	\$666	\$708	\$749	\$787	1.50	40
53 x 30	HETPX.5330YY	\$638	\$717	\$799	\$883	\$927	3.00	44
53 x 36	HETPX.5336YY	\$666	\$760	\$843	\$926	\$972	3.00	49
53 x 42	HETPX.5342YY	\$692	\$802	\$885	\$968	\$1,017	3.00	53
53 x 48	HETPX.5348YY	\$733	\$857	\$940	\$1,023	\$1,074	3.00	56
53 x 60	HETPX.5360YY	\$802	\$956	\$1,038	\$1,121	\$1,177	3.00	63
62 x 24	HETPX.6224YY	\$632	\$695	\$751	\$806	\$847	2.00	42
62 x 30	HETPX.6230YY	\$668	\$748	\$829	\$910	\$998	3.67	45
62 x 36	HETPX.6236YY	\$709	\$793	\$874	\$955	\$1,045	3.67	50
62 x 42	HETPX.6242YY	\$746	\$839	\$920	\$1,002	\$1,094	3.67	60
62 x 48	HETPX.6248YY	\$852	\$896	\$998	\$1,095	\$1,154	3.67	64
62 x 60	HETPX.6260YY	\$1,015	\$999	\$1,100	\$1,201	\$1,262	3.67	74
67 x 24	HETPX.6724YY	\$643	\$707	\$751	\$817	\$858	2.00	43
67 x 30	HETPX.6730YY	\$679	\$750	\$865	\$970	\$1,019	3.80	46
67 x 36	HETPX.6736YY	\$719	\$808	\$913	\$1,018	\$1,068	3.80	51
67 x 42	HETPX.6742YY	\$826	\$855	\$960	\$1,065	\$1,119	3.80	61
67 x 48	HETPX.6748YY	\$965	\$1,017	\$1,018	\$1,123	\$1,179	3.80	65
67 x 60	HETPX.6760YY	\$1,025	\$1,111	\$1,124	\$1,229	\$1,290	3.80	75
85 x 24	HETPX.8524YY	\$695	\$791	\$857	\$923	\$969	2.40	59
85 x 30	HETPX.8530YY	\$764	\$946	\$1,078	\$1,211	\$1,271	4.80	64
85 x 36	HETPX.8536YY	\$846	\$982	\$1,114	\$1,247	\$1,309	4.80	70
85 x 42	HETPX.8542YY	\$903	\$1,016	\$1,148	\$1,280	\$1,344	4.80	76
85 x 48	HETPX.8548YY	\$954	\$1,066	\$1,199	\$1,332	\$1,398	4.80	80
85 x 60	HETPX.8560YY	\$1,093	\$1,145	\$1,278	\$1,410	\$1,481	4.80	89

## A2 NONPOWERED FABRIC HALF GLAZED PANEL

### Product Description

Upper section glazed, lower section fabric covered hard surface panel with nonpowered wire management attached. Includes (1) panel, (2) base covers, & (1) metal base attached.

**PANEL CONNECTORS MUST BE ORDERED SEPARATELY.**

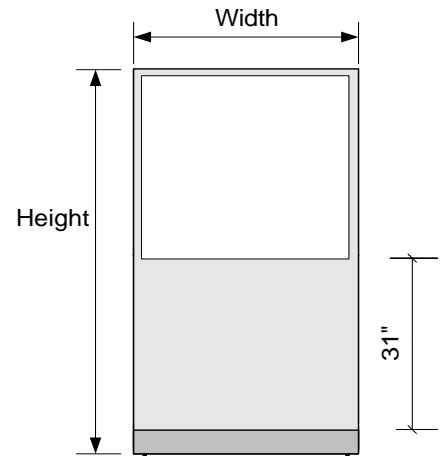
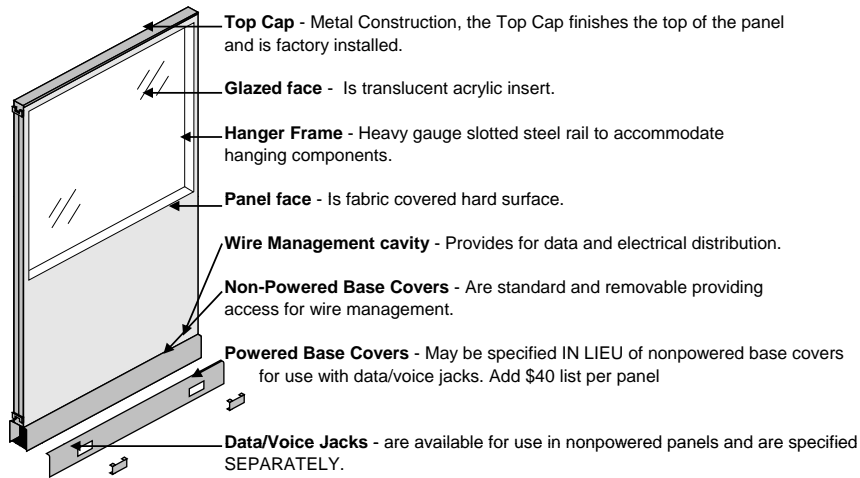

### Actual Dimensions

Depth (Thickness)	2" at top, 3 3/8" at base
Width	24", 30", 36", 42" & 48"
Height (Minimum)	62", 67" & 85"
Wire Management	5"

## A2 NONPOWERED FABRIC HALF GLAZED PANEL

HALF GLAZED FABRIC PANEL WITH CHOICE OF BRONZE OR CLEAR GLAZING

### Specify:

- \* Product number.
- \* Wire Management color – "X" (B=BU,D=DT add +\$25 per panel, M=MT)
- \* Wire Management Option, Raceway with Power Openings and 2 outlets per Add +\$50 per panel -J
- \* Trim color – "YY" (BU, DT, HT, LG, LT, MT)
- \* Fabric name and style number.

### Note:

- \* Order Finished End (Pg. 31) to finish exposed panel end.
- \* Order Panel Connectors (Pgs. 30-31) separately.
- \* Fabric yardage estimate is for directional application (min 66" width).
- \* Special fabrics may affect yardage requirements.

### PANEL WITH BRONZE GLAZING

DIMENSION: H x W	ITEM NUMBER	FABRIC Q COM LIST	FABRIC GRADE 1 LIST	FABRIC GRADE 2 LIST	FABRIC GRADE 3 LIST	FABRIC GRADE 4 LIST	YDG REQ'D	WEIGHT
62 x 24	MEGBRNX.6224YY	\$1,209	\$1,272	\$1,328	\$1,382	\$1,451	2.00	37
62 x 30	MEGBRNX.6230YY	\$1,563	\$1,626	\$1,727	\$1,828	\$1,920	3.67	40
62 x 36	MEGBRNX.6236YY	\$1,621	\$1,684	\$1,785	\$1,887	\$1,981	3.67	46
62 x 42	MEGBRNX.6242YY	\$1,858	\$1,922	\$2,023	\$2,124	\$2,230	3.67	50
62 x 48	MEGBRNX.6248YY	\$1,906	\$1,969	\$2,070	\$2,171	\$2,280	3.67	55
67 x 24	MEGBRNX.6724YY	\$1,394	\$1,457	\$1,512	\$1,568	\$1,646	2.00	38
67 x 30	MEGBRNX.6730YY	\$1,605	\$1,669	\$1,773	\$1,878	\$1,971	3.80	41
67 x 36	MEGBRNX.6736YY	\$1,668	\$1,731	\$1,836	\$1,942	\$2,038	3.80	47
67 x 42	MEGBRNX.6742YY	\$1,900	\$1,964	\$2,068	\$2,173	\$2,282	3.80	51
67 x 48	MEGBRNX.6748YY	\$1,953	\$2,017	\$2,122	\$2,226	\$2,338	3.80	56
85 x 24	MEGBRNX.8524YY	\$1,578	\$1,642	\$1,708	\$1,775	\$1,863	2.40	49
85 x 30	MEGBRNX.8530YY	\$1,826	\$1,890	\$2,022	\$2,155	\$2,263	4.80	55
85 x 36	MEGBRNX.8536YY	\$1,910	\$1,973	\$2,105	\$2,238	\$2,350	4.80	60
85 x 42	MEGBRNX.8542YY	\$2,037	\$2,100	\$2,232	\$2,365	\$2,483	4.80	65
85 x 48	MEGBRNX.8548YY	\$2,228	\$2,291	\$2,424	\$2,556	\$2,684	4.80	69

### PANEL WITH CLEAR GLAZING

DIMENSION: H x W	ITEM NUMBER	FABRIC Q COM LIST	FABRIC GRADE 1 LIST	FABRIC GRADE 2 LIST	FABRIC GRADE 3 LIST	FABRIC GRADE 4 LIST	YDG REQ'D	WEIGHT
62 x 24	MEGCLNX.6224YY	\$1,209	\$1,272	\$1,328	\$1,382	\$1,451	2.00	37
62 x 30	MEGCLNX.6230YY	\$1,563	\$1,626	\$1,727	\$1,828	\$1,920	3.67	40
62 x 36	MEGCLNX.6236YY	\$1,621	\$1,684	\$1,785	\$1,887	\$1,981	3.67	46
62 x 42	MEGCLNX.6242YY	\$1,858	\$1,922	\$2,023	\$2,124	\$2,230	3.67	50
62 x 48	MEGCLNX.6248YY	\$1,906	\$1,969	\$2,070	\$2,171	\$2,280	3.67	55
67 x 24	MEGCLNX.6724YY	\$1,394	\$1,457	\$1,512	\$1,568	\$1,646	2.00	38
67 x 30	MEGCLNX.6730YY	\$1,605	\$1,669	\$1,773	\$1,878	\$1,971	3.80	41
67 x 36	MEGCLNX.6736YY	\$1,668	\$1,731	\$1,836	\$1,942	\$2,038	3.80	47
67 x 42	MEGCLNX.6742YY	\$1,900	\$1,964	\$2,068	\$2,173	\$2,282	3.80	51
67 x 48	MEGCLNX.6748YY	\$1,953	\$2,017	\$2,122	\$2,226	\$2,338	3.80	56
85 x 24	MEGCLNX.8524YY	\$1,578	\$1,642	\$1,708	\$1,775	\$1,863	2.40	49
85 x 30	MEGCLNX.8530YY	\$1,826	\$1,890	\$2,022	\$2,155	\$2,263	4.80	55
85 x 36	MEGCLNX.8536YY	\$1,910	\$1,973	\$2,105	\$2,238	\$2,350	4.80	60
85 x 42	MEGCLNX.8542YY	\$2,037	\$2,100	\$2,232	\$2,365	\$2,483	4.80	65
85 x 48	MEGCLNX.8548YY	\$2,228	\$2,291	\$2,424	\$2,556	\$2,684	4.80	69

## A2 POWERED FABRIC HALF GLAZED PANEL

### Product Description

Upper section glazed, lower section fabric covered hard surface panel with powered wire management attached. Includes (1) panel, (2) base covers, (1) metal base attached, (1) electrical harness & (2) outlet covers. Duplex receptacles and additional outlet covers must be ordered separately.

**PANEL CONNECTORS MUST BE ORDERED SEPARATELY.**

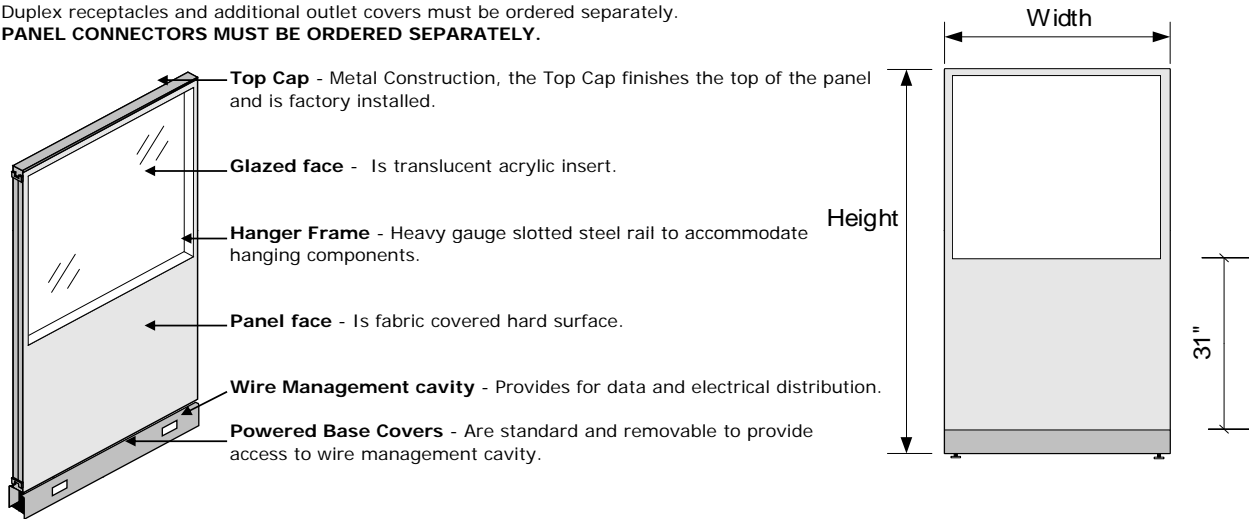

### Actual Dimensions

Depth (Thickness)	2" at top, 3 1/2" at base
Width	24", 30", 36", 42" & 48"
Height (Minimum)	62", 67" & 85"
Wire Management	5"

## A2 POWERED FABRIC HALF GLAZED PANEL

HALF GLAZED FABRIC PANEL WITH CHOICE OF BRONZE OR CLEAR GLAZING

### Specify:

- \* Product number.
- \* Wire Management color – "X" (B=BU,D=DT add +\$25 per panel, M=MT)
- \* Wire Management Option, Raceway with Power Openings and 2 outlets per Add +\$50 per panel -J
- \* Trim color – "YY" (BU, DT, HT, LG, LT, MT)
- \* Fabric name and style number.

### Note:

- \* Includes Electrical Harness.
- \* Order Finished End (Pg. 31) to finish exposed panel end.
- \* Order Panel Connectors (Pgs. 30-31) and Festoons (Pg. 34) separately.
- \* Fabric yardage estimate is for directional application (min 66" width).
- \* Special fabrics may affect yardage requirements.

### PANEL WITH BRONZE GLAZING

DIMENSION: H x W	ITEM NUMBER	FABRIC Q COM LIST	FABRIC GRADE 1 LIST	FABRIC GRADE 2 LIST	FABRIC GRADE 3 LIST	FABRIC GRADE 4 LIST	YDG REQ'D	WEIGHT
62 x 24	MEGBRPX.6224YY	\$1,430	\$1,492	\$1,548	\$1,604	\$1,683	2.00	40
62 x 30	MEGBRPX.6230YY	\$1,792	\$1,856	\$1,957	\$2,059	\$2,162	3.67	42
62 x 36	MEGBRPX.6236YY	\$1,853	\$1,916	\$2,018	\$2,119	\$2,225	3.67	49
62 x 42	MEGBRPX.6242YY	\$2,091	\$2,154	\$2,255	\$2,357	\$2,474	3.67	53
62 x 48	MEGBRPX.6248YY	\$2,138	\$2,201	\$2,302	\$2,404	\$2,525	3.67	58
67 x 24	MEGBRPX.6724YY	\$1,614	\$1,678	\$1,732	\$1,788	\$1,878	2.00	41
67 x 30	MEGBRPX.6730YY	\$1,834	\$1,898	\$2,003	\$2,108	\$2,213	3.80	44
67 x 36	MEGBRPX.6736YY	\$1,900	\$1,964	\$2,068	\$2,173	\$2,282	3.80	50
67 x 42	MEGBRPX.6742YY	\$2,133	\$2,196	\$2,301	\$2,406	\$2,526	3.80	54
67 x 48	MEGBRPX.6748YY	\$2,186	\$2,248	\$2,354	\$2,459	\$2,581	3.80	59
85 x 24	MEGBRPX.8524YY	\$1,799	\$1,862	\$1,928	\$1,068	\$2,095	2.40	52
85 x 30	MEGBRPX.8530YY	\$2,057	\$2,120	\$2,253	\$2,384	\$2,504	4.80	58
85 x 36	MEGBRPX.8536YY	\$2,142	\$2,205	\$2,338	\$2,471	\$2,594	4.80	63
85 x 42	MEGBRPX.8542YY	\$2,269	\$2,332	\$2,465	\$2,609	\$2,727	4.80	68
85 x 48	MEGBRPX.8548YY	\$2,460	\$2,524	\$2,655	\$2,788	\$2,927	4.80	72

### PANEL WITH CLEAR GLAZING

DIMENSION: H x W	ITEM NUMBER	FABRIC Q COM LIST	FABRIC GRADE 1 LIST	FABRIC GRADE 2 LIST	FABRIC GRADE 3 LIST	FABRIC GRADE 4 LIST	YDG REQ'D	WEIGHT
62 x 24	MEGCLPX.6224YY	\$1,430	\$1,492	\$1,548	\$1,604	\$1,683	2.00	40
62 x 30	MEGCLPX.6230YY	\$1,792	\$1,856	\$1,957	\$2,059	\$2,162	3.67	42
62 x 36	MEGCLPX.6236YY	\$1,853	\$1,916	\$2,018	\$2,119	\$2,225	3.67	49
62 x 42	MEGCLPX.6242YY	\$2,091	\$2,154	\$2,255	\$2,357	\$2,474	3.67	53
62 x 48	MEGCLPX.6248YY	\$2,138	\$2,201	\$2,302	\$2,404	\$2,525	3.67	58
67 x 24	MEGCLPX.6724YY	\$1,614	\$1,678	\$1,732	\$1,788	\$1,878	2.00	41
67 x 30	MEGCLPX.6730YY	\$1,834	\$1,898	\$2,003	\$2,108	\$2,213	3.80	44
67 x 36	MEGCLPX.6736YY	\$1,900	\$1,964	\$2,068	\$2,173	\$2,282	3.80	50
67 x 42	MEGCLPX.6742YY	\$2,133	\$2,196	\$2,301	\$2,406	\$2,526	3.80	54
67 x 48	MEGCLPX.6748YY	\$2,186	\$2,248	\$2,354	\$2,459	\$2,581	3.80	59
85 x 24	MEGCLPX.8524YY	\$1,799	\$1,862	\$1,928	\$1,068	\$2,095	2.40	52
85 x 30	MEGCLPX.8530YY	\$2,057	\$2,120	\$2,253	\$2,384	\$2,504	4.80	58
85 x 36	MEGCLPX.8536YY	\$2,142	\$2,205	\$2,338	\$2,471	\$2,594	4.80	63
85 x 42	MEGCLPX.8542YY	\$2,269	\$2,332	\$2,465	\$2,609	\$2,727	4.80	68
85 x 48	MEGCLPX.8548YY	\$2,460	\$2,524	\$2,655	\$2,788	\$2,927	4.80	72

## A2 NON-POWERED FABRIC STACKING GLAZED PANEL, SINGLE OPENING

STACKING GLAZED FABRIC PANEL WITH CHOICE OF BRONZE OR CLEAR GLAZING 14" OPENING

### Specify:

- \* Product number.
- \* Wire Management color – "X" (B=BU,D=DT add +\$25 per panel, M=MT)
- \* Wire Management Option, Raceway with Power Openings and 2 outlets per Add +\$50 per panel -J
- \* Trim color – "YY" (BU, DT, HT, LG, LT, MT)
- \* Insert Color to match panel frame.
- \* Fabric name and style number.



### Note:

- \* Order Finished End (Pg. 31) to finish exposed panel end.
- \* Order Panel Connectors (Pgs. 30-31) separately.
- \* Fabric yardage estimate is for directional application (min 66" width).
- \* Special fabrics may affect yardage requirements.

### PANEL WITH BRONZE GLAZING, BU STACK INSERT

DIMENSION: H x W	ITEM NUMBER	FABRIC Q COM LIST	FABRIC GRADE 1 LIST	FABRIC GRADE 2 LIST	FABRIC GRADE 3 LIST	FABRIC GRADE 4 LIST	YDG REQ'D	WEIGHT
53 x 24	HESSNBRx.5324yy	\$941	\$975	\$1,009	\$1,044	\$1,067	1.25	55
53 x 30	HESSNBRx.5330yy	\$1,009	\$1,042	\$1,104	\$1,166	\$1,194	2.25	61
53 x 36	HESSNBRx.5336yy	\$1,110	\$1,142	\$1,204	\$1,267	\$1,296	2.25	66
53 x 42	HESSNBRx.5342yy	\$1,205	\$1,236	\$1,298	\$1,360	\$1,391	2.25	74
53 x 48	HESSNBRx.5348yy	\$1,261	\$1,291	\$1,335	\$1,415	\$1,447	2.25	81
67 x 24	HESSNBRx.6724yy	\$958	\$1,012	\$1,064	\$1,095	\$1,120	1.50	65
67 x 30	HESSNBRx.6730yy	\$1,046	\$1,100	\$1,202	\$1,266	\$1,298	3.00	73
67 x 36	HESSNBRx.6736yy	\$1,187	\$1,237	\$1,331	\$1,403	\$1,439	3.00	84
67 x 42	HESSNBRx.6742yy	\$1,286	\$1,337	\$1,438	\$1,503	\$1,540	3.00	93
67 x 48	HESSNBRx.6748yy	\$1,359	\$1,408	\$1,513	\$1,574	\$1,613	3.00	103

### PANEL WITH CLEAR GLAZING, BU STACK INSERT

DIMENSION: H x W	ITEM NUMBER	FABRIC Q COM LIST	FABRIC GRADE 1 LIST	FABRIC GRADE 2 LIST	FABRIC GRADE 3 LIST	FABRIC GRADE 4 LIST	YDG REQ'D	WEIGHT
53 x 24	HESSNCLx.5324yy	\$941	\$975	\$1,009	\$1,044	\$1,067	1.25	55
53 x 30	HESSNCLx.5330yy	\$1,009	\$1,042	\$1,104	\$1,166	\$1,194	2.25	61
53 x 36	HESSNCLx.5336yy	\$1,110	\$1,142	\$1,204	\$1,267	\$1,296	2.25	66
53 x 42	HESSNCLx.5342yy	\$1,205	\$1,236	\$1,298	\$1,360	\$1,391	2.25	74
53 x 48	HESSNCLx.5348yy	\$1,261	\$1,291	\$1,335	\$1,415	\$1,447	2.25	81
67 x 24	HESSNCLx.6724yy	\$958	\$1,012	\$1,064	\$1,095	\$1,120	1.50	65
67 x 30	HESSNCLx.6730yy	\$1,046	\$1,100	\$1,202	\$1,266	\$1,298	3.00	73
67 x 36	HESSNCLx.6736yy	\$1,187	\$1,237	\$1,331	\$1,403	\$1,439	3.00	84
67 x 42	HESSNCLx.6742yy	\$1,286	\$1,337	\$1,438	\$1,503	\$1,540	3.00	93
67 x 48	HESSNCLx.6748yy	\$1,359	\$1,408	\$1,513	\$1,574	\$1,613	3.00	103

## A2 NON-POWERED FABRIC STACKING GLAZED PANEL, DOUBLE OPENING

STACKING GLAZED FABRIC PANEL WITH CHOICE OF BRONZE OR CLEAR GLAZING 2 14" OPENINGS

### Specify:

- \* Product number.
- \* Wire Management color – "X" (B=BU,D=DT add +\$25 per panel, M=MT)
- \* Wire Management Option, Raceway with Power Openings and 2 outlets per Add +\$50 per panel -J
- \* Trim color – "YY" (BU, DT, HT, LG, LT, MT)
- \* Insert Color to match panel frame.
- \* Fabric name and style number.



### Note:

- \* Order Finished End (Pg. 30) to finish exposed panel end.
- \* Order Panel Connectors (Pgs. 30-31) separately.
- \* Fabric yardage estimate is for directional application (min 66" width).
- \* Special fabrics may affect yardage requirements.

### PANEL WITH BRONZE GLAZING, BU STACK INSERT

DIMENSION: H x W	ITEM NUMBER	FABRIC Q COM LIST	FABRIC GRADE 1 LIST	FABRIC GRADE 2 LIST	FABRIC GRADE 3 LIST	FABRIC GRADE 4 LIST	YDG REQ'D	WEIGHT
67 x 24	HEDSNBRx.6724yy	\$1,209	\$1,243	\$1,277	\$1,312	\$1,335	1.25	105
67 x 30	HEDSNBRx.6730yy	\$1,267	\$1,300	\$1,362	\$1,423	\$1,451	2.25	113
67 x 36	HEDSNBRx.6736yy	\$1,342	\$1,374	\$1,436	\$1,499	\$1,527	2.25	124
67 x 42	HEDSNBRx.6742yy	\$1,391	\$1,421	\$1,483	\$1,545	\$1,576	2.25	133
67 x 48	HEDSNBRx.6748yy	\$1,431	\$1,461	\$1,523	\$1,585	\$1,617	2.25	143

### PANEL WITH CLEAR GLAZING, BU STACK INSERT

DIMENSION: H x W	ITEM NUMBER	FABRIC Q COM LIST	FABRIC GRADE 1 LIST	FABRIC GRADE 2 LIST	FABRIC GRADE 3 LIST	FABRIC GRADE 4 LIST	YDG REQ'D	WEIGHT
67 x 24	HEDSNCLx.6724yy	\$1,209	\$1,243	\$1,277	\$1,312	\$1,335	1.25	105
67 x 30	HEDSNCLx.6730yy	\$1,267	\$1,300	\$1,362	\$1,423	\$1,451	2.25	113
67 x 36	HEDSNCLx.6736yy	\$1,342	\$1,374	\$1,436	\$1,499	\$1,527	2.25	124
67 x 42	HEDSNCLx.6742yy	\$1,391	\$1,421	\$1,483	\$1,545	\$1,576	2.25	133
67 x 48	HEDSNCLx.6748yy	\$1,431	\$1,461	\$1,523	\$1,585	\$1,617	2.25	1432

## A2 POWERED FABRIC STACKING GLAZED PANEL, SINGLE OPENING

STACKING GLAZED FABRIC PANEL WITH CHOICE OF BRONZE OR CLEAR GLAZING 14" OPENING

### Specify:

- \* Product number.
- \* Wire Management color – "X" (B=BU,D=DT add +\$25 per panel, M=MT)
- \* Trim color – "YY" (BU, DT, HT, LG, LT, MT)
- \* Insert Color to match panel frame.
- \* Fabric name and style number.



### Note:

- \* Includes Electrical Harness.
- \* Order Finished End (Pg. 31) to finish exposed panel end.
- \* Order Panel Connectors (Pgs. 30-31) and Festoons (Pg. 34) separately.
- \* Fabric yardage estimate is for directional application (min 66" width).
- \* Special fabrics may affect yardage requirements.

### PANEL WITH BRONZE GLAZING, BU STACK INSERT

DIMENSION: H x W	ITEM NUMBER	FABRIC Q COM LIST	FABRIC GRADE 1 LIST	FABRIC GRADE 2 LIST	FABRIC GRADE 3 LIST	FABRIC GRADE 4 LIST	YDG REQ'D	WEIGHT
53 x 24	HESSPBRx.5324yy	\$1,115	\$1,133	\$1,167	\$1,202	\$1,232	1.25	60
53 x 30	HESSPBRx.5330yy	\$1,185	\$1,200	\$1,262	\$1,324	\$1,359	2.25	66
53 x 36	HESSPBRx.5336yy	\$1,285	\$1,299	\$1,361	\$1,422	\$1,461	2.25	71
53 x 42	HESSPBRx.5342yy	\$1,381	\$1,393	\$1,455	\$1,517	\$1,556	2.25	79
53 x 48	HESSPBRx.5348yy	\$1,439	\$1,449	\$1,511	\$1,574	\$1,614	2.25	86
67 x 24	HESSPBRx.6724yy	\$1,154	\$1,169	\$1,211	\$1,252	\$1,284	1.50	70
67 x 30	HESSPBRx.6730yy	\$1,222	\$1,257	\$1,339	\$1,422	\$1,462	3.00	78
67 x 36	HESSPBRx.6736yy	\$1,353	\$1,384	\$1,467	\$1,549	\$1,593	3.00	89
67 x 42	HESSPBRx.6742yy	\$1,466	\$1,495	\$1,577	\$1,660	\$1,706	3.00	98
67 x 48	HESSPBRx.6748yy	\$1,539	\$1,566	\$1,648	\$1,730	\$1,779	3.00	108

### PANEL WITH CLEAR GLAZING, BU STACK INSERT

DIMENSION: H x W	ITEM NUMBER	FABRIC Q COM LIST	FABRIC GRADE 1 LIST	FABRIC GRADE 2 LIST	FABRIC GRADE 3 LIST	FABRIC GRADE 4 LIST	YDG REQ'D	WEIGHT
53 x 24	HESSPCLx.5324yy	\$1,115	\$1,133	\$1,167	\$1,202	\$1,232	1.25	60
53 x 30	HESSPCLx.5330yy	\$1,185	\$1,200	\$1,262	\$1,324	\$1,359	2.25	66
53 x 36	HESSPCLx.5336yy	\$1,285	\$1,299	\$1,361	\$1,422	\$1,461	2.25	71
53 x 42	HESSPCLx.5342yy	\$1,381	\$1,393	\$1,455	\$1,517	\$1,556	2.25	79
53 x 48	HESSPCLx.5348yy	\$1,439	\$1,449	\$1,511	\$1,574	\$1,614	2.25	86
67 x 24	HESSPCLx.6724yy	\$1,154	\$1,169	\$1,211	\$1,252	\$1,284	1.50	70
67 x 30	HESSPCLx.6730yy	\$1,222	\$1,257	\$1,339	\$1,422	\$1,462	3.00	78
67 x 36	HESSPCLx.6736yy	\$1,353	\$1,384	\$1,467	\$1,549	\$1,593	3.00	89
67 x 42	HESSPCLx.6742yy	\$1,466	\$1,495	\$1,577	\$1,660	\$1,706	3.00	98
67 x 48	HESSPCLx.6748yy	\$1,539	\$1,566	\$1,648	\$1,730	\$1,779	3.00	1082

## A2 POWERED FABRIC STACKING GLAZED PANEL, DOUBLE OPENING

STACKING GLAZED FABRIC PANEL WITH CHOICE OF BRONZE OR CLEAR GLAZING 2 14" OPENINGS

### Specify:

- \* Product number.
- \* Wire Management color – "X" (B=BU,D=DT add +\$25 per panel, M=MT)
- \* Trim color – "YY" (BU, DT, HT, LG, LT, MT)
- \* Insert Color to match panel frame.
- \* Fabric name and style number.



### Note:

- \* Includes Electrical Harness.
- \* Order Finished End (Pg. 31) to finish exposed panel end.
- \* Order Panel Connectors (Pgs. 30-31) and Festoons (Pg. 34) separately.
- \* Fabric yardage estimate is for directional application (min 66" width).
- \* Special fabrics may affect yardage requirements.

### PANEL WITH BRONZE GLAZING, BU STACK INSERT

DIMENSION: H x W	ITEM NUMBER	FABRIC Q COM LIST	FABRIC GRADE 1 LIST	FABRIC GRADE 2 LIST	FABRIC GRADE 3 LIST	FABRIC GRADE 4 LIST	YDG REQ'D	WEIGHT
67 x 24	HEDSPBRx.6724yy	\$1,416	\$1,432	\$1,474	\$1,515	\$1,547	1.25	105
67 x 30	HEDSPBRx.6730yy	\$1,474	\$1,509	\$1,591	\$1,675	\$1,714	2.25	113
67 x 36	HEDSPBRx.6736yy	\$1,580	\$1,611	\$1,693	\$1,776	\$1,820	2.25	124
67 x 42	HEDSPBRx.6742yy	\$1,646	\$1,675	\$1,757	\$1,841	\$1,886	2.25	133
67 x 48	HEDSPBRx.6748yy	\$1,704	\$1,730	\$1,813	\$1,895	\$1,944	2.25	143

### PANEL WITH CLEAR GLAZING, BU STACK INSERT

DIMENSION: H x W	ITEM NUMBER	FABRIC Q COM LIST	FABRIC GRADE 1 LIST	FABRIC GRADE 2 LIST	FABRIC GRADE 3 LIST	FABRIC GRADE 4 LIST	YDG REQ'D	WEIGHT
67 x 24	HEDSPCLx.6724yy	\$1,416	\$1,432	\$1,474	\$1,515	\$1,547	1.25	105
67 x 30	HEDSPCLx.6730yy	\$1,474	\$1,509	\$1,591	\$1,675	\$1,714	2.25	113
67 x 36	HEDSPCLx.6736yy	\$1,580	\$1,611	\$1,693	\$1,776	\$1,820	2.25	124
67 x 42	HEDSPCLx.6742yy	\$1,646	\$1,675	\$1,757	\$1,841	\$1,886	2.25	133
67 x 48	HEDSPCLx.6748yy	\$1,704	\$1,730	\$1,813	\$1,895	\$1,944	2.25	143

## A2 DOOR PANEL

**Specify:**

- \* Product number.
- \* Door color – "YY" (BU, DT, HT, LG, LT, MT)
- \* Trim color – "YY" (BU, DT, HT, LG, LT, MT)
- \* Bronze or clear glazing.

**Note:**

- \* Includes laminated door, bronze or clear glazed side panel, painted steel frame, and locking door knob with hardware.
- \* Shipped assembled.
- \* Lock set must be field installed.

ITEM DESCRIPTION	ITEM NUMBER	HEIGHT	WIDTH	LIST PRICE	WEIGHT
LEFT-HAND DOOR	HMDPEL.8548YY	85"	48"	\$ 3,378.00	105
RIGHT-HAND DOOR	HMDPER.8548YY	85"	48"	\$ 3,378.00	105

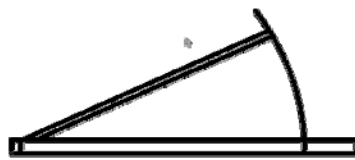
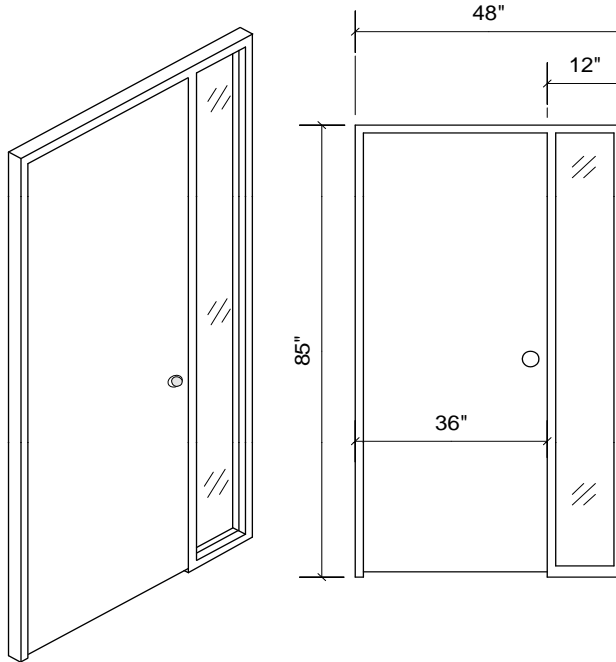

Left Hand Swing

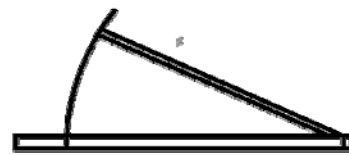

Right Hand Swing



## A2 PANEL CONNECTORS

### Specify:

- \* Product number.
- \* Trim color – "YY" (BU, DT, HT, LG, LT, MT)
- \* Wire Management color – "X" (B=BU, D=DT (Add \$15 list per connector), M=MT)

### Note:

- \* Connectors include Wire Management Trim.

### TWO WAY 90 CONNECTOR

CONNECTS TWO PANELS AT 90 DEGREES.

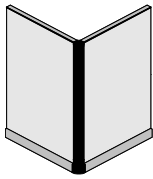

DIMENSIONS HEIGHT	ITEM NUMBER	LIST PRICE	WEIGHT
39"	HME2CX.39YY	\$126	5
47"	HME2CX.47YY	\$137	6
53"	HME2CX.53YY	\$140	7
62"	HME2CX.62YY	\$148	8
67"	HME2CX.67YY	\$151	8
85"	HME2CX.85YY	\$164	10

### THREE WAY CONNECTOR

CONNECTS THREE PANELS AT A "T".

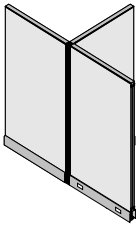

DIMENSION: HEIGHT	ITEM NUMBER		WEIGHT
39"	HME3CX.39YY	\$184	7
47"	HME3CX.47YY	\$200	8
53"	HME3CX.53YY	\$210	9
62"	HME3CX.62YY	\$221	10
67"	HME3CX.67YY	\$230	10
85"	HME3CX.85YY	\$259	12

### FOUR WAY CONNECTOR

CONNECTS FOUR PANELS AT AN INTERSECTION.

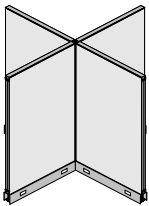

DIMENSION: HEIGHT	ITEM NUMBER		WEIGHT
39"	HME4C.39YY	\$181	9
47"	HME4C.47YY	\$210	10
53"	HME4C.53YY	\$215	11
62"	HME4C.62YY	\$243	12
67"	HME4C.67YY	\$249	12
85"	HME4C.85YY	\$269	14

### PANEL CONNECTOR ROD - DT ONLY

CONNECTS TWO PANELS IN A STRAIGHT LINE.

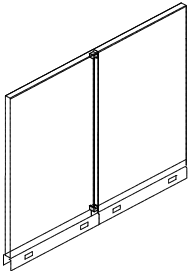

DIMENSION: HEIGHT	ITEM NUMBER		WEIGHT
39"	HMPC.39	\$35	2
47"	HMPC.47	\$36	2
53"	HMPC.53	\$36	2
62"	HMPC.62B	\$37	2
67"	HMPC.67	\$37	2
85"	HMPC.85	\$39	2

## A2 PANEL CONNECTORS

### Specify:

- \* Product number.
- \* Trim color – "YY" (BU, DT, HT, LG, LT, MT)
- \* Wire Management color – "X" (B=BU, D=DT (Add \$15 list per connector), M=MT)

### T-CONNECTOR (WALL START)

CONNECTS PANEL TO AN EXISTING STRUCTURAL WALL TO BEGIN A PANEL RUN, INCLUDES ONE (1) CONNECTOR ROD (SEE ABOVE)  
ORDER WALL FASTENERS (see below) SEPARATELY.

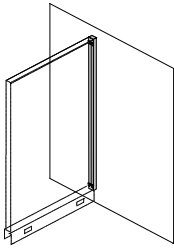

DIMENSION: HEIGHT	ITEM NUMBER	LIST PRICE	WEIGHT
39"	HMTC.39YY	\$85	6
47"	HMTC.47YY	\$89	6
53"	HMTC.53YY	\$92	7
62"	HMTC.62YY	\$97	8
67"	HMTC.67YY	\$98	8
85"	HMTC.85YY	\$103	9
ANCHOR KIT (4)	HMWF.4	\$16	2

### FINISHED END

FINISHES EXPOSED PANEL END. WIRE MANAGEMENT TRIM INCLUDED.

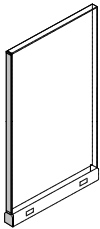

DIMENSION: HEIGHT	ITEM NUMBER	LIST PRICE	WEIGHT
39"	HMEECX.39YY	\$55	3
47"	HMEECX.47YY	\$59	3
53"	HMEECX.53YY	\$60	3
62"	HMEECX.62YY	\$62	4
67"	HMEECX.67YY	\$64	4
85"	HMEECX.85YY	\$69	5

### TWO WAY 180 DEGREE CONNECTOR

CONNECTS PANELS OF EQUAL OR UNEQUAL HEIGHTS FOR DIMENSIONAL GAIN. USE ONLY IN SPECIAL CONDITIONS

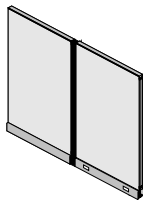

DIMENSION: HEIGHT	ITEM NUMBER	LIST PRICE	WEIGHT
39"	HME180CX.39YY	\$232	5
47"	HME180CX.47YY	\$251	6
53"	HME180CX.53YY	\$264	7
62"	HME180CX.62YY	\$277	8
67"	HME180CX.67YY	\$287	8
85"	HME180CX.85YY	\$322	10

## A2 PANEL COMPONENTS

**Specify:**

\* Product number.

### WALL HANGER STRIP

HIGH QUALITY BRUSHED ALUMINUM EXTRUSION WITH HEAVY DUTY 16 GAUGE STEEL SLOTTED INSERT IS USED TO HANG COMPONENTS OR WORK SURFACES DIRECTLY FROM A WALL. ORDER WALL FASTENERS (SEE BELOW) SEPARATELY. NATURAL ALUMINUM COLOR ONLY  
PRICING IS PER STRIP, PICTURE SHOWS APPLICATION ONLY.

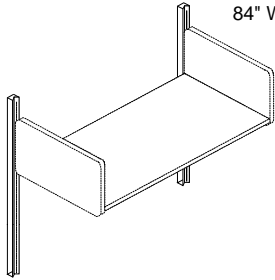

ITEM DESCRIPTION	ITEM NUMBER	LIST PRICE		WEIGHT
60" WALL HANGER STRIP	HMWHS.60	\$92	Each Strip	3
72" WALL HANGER STRIP	HMWHS.72	\$98	Each Strip	4
84" WALL HANGER STRIP	HMWHS.84	\$108	Each Strip	4

### WALL FASTENERS

USE TO FASTEN A T-CONNECTOR OR WALL HANGER STRIP TO AN EXISTING WALL.

ITEM DESCRIPTION	ITEM NUMBER	LIST PRICE	WEIGHT
3/16" TOGGLE BOLT ANCHOR	HMWF.1	\$3	1
3/16" x 3" FLAT HEAD TOGGLE BOLT ANCHOR KIT (12)	HMWF.2	\$1	1
	HMWF.3	\$49	12

### VARIABLE HEIGHT FILLER STRIP - RIGID

FINISHES EXPOSED END OF CONNECTOR OR PANEL WHEN JOINING PANELS OF DIFFERENT HEIGHTS. CUT TO LENGTH AS REQUIRED.

\* Trim color – "YY" (BU, DT, HT, LG, LT, MT). Color is for Filler Strip only.

ITEM DESCRIPTION	ITEM NUMBER	LIST PRICE	WEIGHT
VARIABLE HEIGHT PKG - 42" LENGTH	HMVHYY	\$29	1

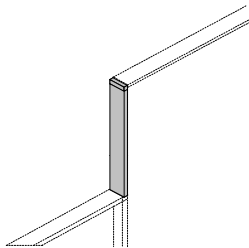



## A2 ENERGY COMPONENTS

**Specify:**







- \* Product number.
- \* Product color -"YY" (BU, DT (Add \$15 list each), MT)

**Notes: For Powered Wire Management Covers**

- \* Includes (2) Covers.
- \* Order Electrical Harness, Festoons, and Outlet Covers separately (See Below).

### CONVERSION FROM NONPOWERED TO POWERED WIRE MANAGEMENT

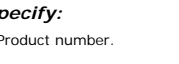
REPLACES NON-POWERED COVERS ALLOWING CONVERSION TO POWERED CAPABILITIES.

ITEM DESCRIPTION	ITEM NUMBER	LIST PRICE	WEIGHT
 24" POWERED COVERS	HMEPWM.24YY	\$36	1
 30" POWERED COVERS	HMEPWM.30YY	\$40	1.2
 36" POWERED COVERS	HMEPWM.36YY	\$44	1.6
 42" POWERED COVERS	HMEPWM.42YY	\$49	1.8
 48" POWERED COVERS	HMEPWM.48YY	\$53	2
 60" POWERED COVERS	HMEPWM.60YY	\$63	2.5
OUTLET COVER	HMEOC.YY	\$8	1

**Specify:**

- \* Product number.

### 8 WIRE 4 CIRCUIT ELECTRICAL HARNESS

USE WITH POWERED WIRE MANAGEMENT TO DISTRIBUTE 4 OPEN 20 AMP CIRCUITS. UP TO FOUR RECEPTACLES CAN BE PLACED ON EACH PANEL. ORDER FESTOON CABLES SEPARATELY. (SEE BELOW)

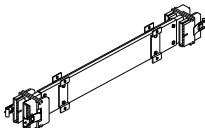
ITEM DESCRIPTION	ITEM NUMBER	LIST PRICE	WEIGHT
 24"	HM8WP.24	\$197	2
30"	HM8WP.30	\$210	2
36"	HM8WP.36	\$221	2
42"	HM8WP.42	\$231	3
48"	HM8WP.48	\$238	4
60"	HM8WP.60	\$267	5

### FESTOONS

CONNECTS POWER BETWEEN PANELS ONLY, OR BETWEEN PANELS CONNECTED BY A 2-WAY, 3-WAY, 4-WAY, OR SPACER POST.

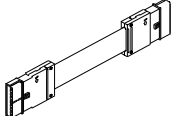
ITEM DESCRIPTION	ITEM NUMBER	LIST PRICE	WEIGHT
 11" PANEL TO PANEL	HM8.PTP	\$79	2
14" PANEL THRU POST	HM8.PTC	\$93	2

## A2 ENERGY COMPONENTS

### Specify:

- \* Product number.
- \* Receptacle color – "YY" (BK)

### PASS THRU JUMPERS

USE THIS FLEXIBLE CONDUIT CABLE TO PASS POWER THROUGH A NONPOWERED PANEL TO CONNECT WITH ANOTHER ELECTRICAL HARNESS.

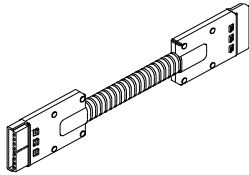

PANEL WIDTH	ITEM NUMBER	LIST PRICE	WEIGHT
12"	HM8PJ.12	\$180	2
18"	HM8PJ.18	\$191	2
24"	HM8PJ.24	\$201	2
30"	HM8PJ.30	\$211	3
36"	HM8PJ.36	\$221	3
42"	HM8PJ.42	\$227	3
48"	HM8PJ.48	\$232	5
60"	HM8PJ.60	\$422	5
72"	HM8PJ.72	\$427	5
84"	HM8PJ.84	\$438	7
96"	HM8PJ.96	\$469	7
108"	HM8PJ.108	\$489	7
132"	HM8PJ.132	\$510	10

### POWER ENTRY

CONNECTS A BUILDING'S ELECTRICAL SUPPLY FROM THE CEILING, WALL, OR FLOOR TO THE BASE OF A PANEL.

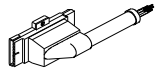

ITEM DESCRIPTION	ITEM NUMBER	LIST PRICE	WEIGHT
72" POWER FEED-RIGHT	HM8PFR.72	\$222	4
72" POWER FEED-LEFT	HM8PFL.72	\$222	4

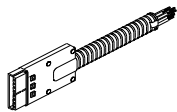

144" CEILING INFEEED	HM8CF.144	\$184	5
----------------------	-----------	-------	---

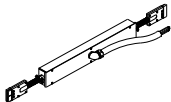

NY Base in Feed Designed for 30" Panel Entry cable not included (supplied by local electrician)	HM8.NYPF30	\$1,118	15
---	------------	---------	----

### 8 WIRE, 4 CIRCUIT ELECTRICAL RECEPTACLES

PLUGS INTO THE ELECTRICAL HARNESS. SELECT CIRCUITS 1, 2, 3, DC.

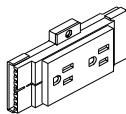

ITEM DESCRIPTION	ITEM NUMBER	LIST PRICE	WEIGHT
CIRCUIT 1	HM8C1.BU	\$32	1
CIRCUIT 2	HM8C2.BU	\$32	1
CIRCUIT 3	HM8C3.BU	\$32	1
DEDICATED CIRCUIT (orange delta)	HM8DC.BU	\$32	1

## A2 ENERGY COMPONENTS

**Specify:**

- \* Product number.
- \* Product color - "YY" ((BU, MT, LG)

**BASIC POWER POLES**

HOLLOW, 2" x 2" RIGID 11 FOOT PVC EXTRUSION USED TO CONCEAL CEILING POWER INFEED, OR COMMUNICATION AND DATA DISTRIBUTION CABLES. HARDWARE INCLUDED TO MOUNT POLE TO END OF PANEL RUN. ORDER BY SIZE OF CONNECTING PANEL. DOES NOT HAVE SEPARATION OF DATA & POWER

ORDER CEILING POWER INFEED (Pg. 31) SEPARATELY.



ITEM DESCRIPTION	ITEM NUMBER	LIST PRICE	WEIGHT
POWER POLE ONLY	HMPP.YY	\$216	15
POWER POLE with hardware	HM8PP.39YY	\$247	20
POWER POLE with hardware	HM8PP.47YY	\$258	20
POWER POLE with hardware	HM8PP.53YY	\$268	20
POWER POLE with hardware	HM8PP.62YY	\$278	22
POWER POLE with hardware	HM8PP.67YY	\$288	23
POWER POLE with hardware	HM8PP.85YY	\$298	25

**LARGE POWER POLES**

HOLLOW, 3" x 4" RIGID 12 FOOT PVC EXTRUSION USED TO CONCEAL CEILING POWER INFEED, OR COMMUNICATION AND DATA DISTRIBUTION CABLES. INCLUDES BASE TRIM AND CEILING BEZEL. DOES NOT INCLUDE PANEL CONNECTING HARDWARE. DOES NOT HAVE SEPARATION OF DATA & POWER. FIELD ADAPT FOR INSTALLATION, SCREW TO CONNECTOR, INSTALLER MUST PROVIDE MOUNTING SCREW AND DRILL BIT.

ORDER CEILING POWER INFEED (Pg. 31) SEPARATELY.



ITEM DESCRIPTION	ITEM NUMBER	LIST PRICE	WEIGHT
POWER POLE Black Umber	HMLPP.BU	\$216	25
POWER POLE Medium Tone	HMLPP.MT	\$216	25
POWER POLE with hardware	HMLPP.39yy	\$247	35
POWER POLE with hardware	HMLPP.47yy	\$258	45
POWER POLE with hardware	HMLPP.53yy	\$268	55
POWER POLE with hardware	HMLPP.62yy	\$278	65
POWER POLE with hardware	HMLPP.67yy	\$288	70
POWER POLE with hardware	HMLPP.85yy	\$298	75

NOTE: This product is available in BU and MT Only



## A2 WORK SURFACE TOPS ONLY

**Specify:**

- \* Product number.
- \* Edge finishes (BU, DT, HT, LG, LT, MT)
- \* Laminate finishes (Pg. 7)
- \* Special laminate colors available upon request.

**Note:**

- \* Tops only, with 3 mm vinyl edge. xXphusion tops are similar in appearance with xXphusion wrap on edges
- \* Order Supports and mounting hardware (Pg.40) separately.

### RECTANGULAR WORK SURFACE TOPS

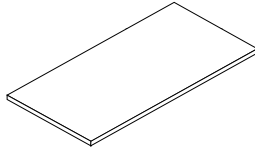
DIMENSION: L x DEPTH	ITEM NUMBER	STD LAMINATE	PREMIUM LAM	xXPHUSION	WEIGHT	
		LIST PRICE	LIST PRICE	LIST PRICE		
	24 x 24	EWS.2424	\$237	\$261	\$237	24
	30 x 24	EWS.3024	\$298	\$327	\$298	29
	36 x 24	EWS.3624	\$308	\$339	\$308	34
	42 x 24	EWS.4224	\$375	\$412	\$375	39
	48 x 24	EWS.4824	\$402	\$442	\$402	44
	54 x 24	EWS.5424	\$468	\$514	\$468	49
	60 x 24	EWS.6024	\$510	\$561	\$510	54
	66 x 24	EWS.6624	\$543	\$597	\$543	64
	72 x 24	EWS.7224	\$582	\$640	\$582	69
	78 x 24	EWS.7824	\$699	\$769	\$699	79
	84 x 24	EWS.8424	\$710	\$781	\$710	85
	90 x 24	EWS.9024	\$809	\$889	\$809	89
	96 x 24	EWS.9624	\$819	\$901	\$819	99
	24 x 30	EWS.2430	\$309	\$340	\$309	32
	30 x 30	EWS.3030	\$351	\$386	\$351	37
	36 x 30	EWS.3630	\$407	\$448	\$407	42
	42 x 30	EWS.4230	\$448	\$493	\$448	47
	48 x 30	EWS.4830	\$460	\$507	\$460	52
	54 x 30	EWS.5430	\$518	\$570	\$518	62
	60 x 30	EWS.6030	\$572	\$629	\$572	67
	66 x 30	EWS.6630	\$630	\$693	\$630	77
	72 x 30	EWS.7230	\$693	\$762	\$693	82
	78 x 30	EWS.7830	\$758	\$834	\$758	87
	84 x 30	EWS.8430	\$768	\$846	\$768	97
	90 x 30	EWS.9030	\$874	\$962	\$874	107
	96 x 30	EWS.9630	\$885	\$973	\$885	117

### CORNER WORK SURFACE TOPS

USE FOR 90 DEGREE CORNERS. GRAIN DIRECTION 45 DEGREE, EXCEPT ON xXPHUSION TOPS THEY ARE 90 DEGREE

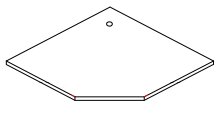
DIMENSION: W x DEPTH	ITEM NUMBER	STD LAMINATE	PREMIUM LAM	xXPHUSION	WEIGHT	
		LIST PRICE	LIST PRICE	LIST PRICE		
	36 x 24	ECWS.3624	\$557	\$613	\$557	49
	42 x 24	ECWS.4224	\$630	\$693	\$630	67
	48 x 24	ECWS.4824	\$668	\$735	\$668	88
36 x 24 36 x 30 42 x 30	36 x 30	ECWS.3630	\$561	\$618	\$561	53
	42 x 30	ECWS.4230	\$645	\$710	\$645	70
	48 x 30	ECWS.4830	\$690	\$759	\$690	91

### CORNER WORK SURFACE TOPS INSIDE CURVE

USE FOR 90 DEGREE CORNERS. GRAIN DIRECTION 90 DEGREE

DIMENSION: W x DEPTH	ITEM NUMBER	STD LAMINATE	PREMIUM LAM	xXPHUSION	WEIGHT	
		LIST PRICE	LIST PRICE	LIST PRICE		
	36 x 24	ECCWS.3624	\$546	\$600	\$546	49
	42 x 24	ECCWS.4224	\$617	\$679	\$617	67
	48 x 24	ECCWS.4824	\$658	\$724	\$658	88
	36 x 30	ECCWS.3630	\$551	\$607	\$551	53
	42 x 30	ECCWS.4230	\$628	\$691	\$628	70
	48 x 30	ECCWS.4830	\$675	\$743	\$675	91

## A2 WORK SURFACE TOPS ONLY

**Specify:**

- \* Product number.
- \* Edge finishes (BU, DT, HT, LG, LT, MT)
- \* Laminate finishes (Pg. 7)
- \* Special laminate colors available upon request.

**Note:**

- \* Tops only, with 3 mm vinyl edge. xXphusion tops are similar in appearance with xXphusion wrap on edges
- \* Order Supports and mounting hardware (Pg. 40) separately.

### PENINSULA WORK SURFACE TOPS

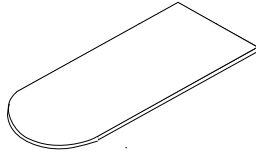

DIMENSION: W x DEPTH	ITEM NUMBER	STD LAMINATE	PREMIUM LAM	xXPHUSION	WEIGHT
		LIST PRICE	LIST PRICE	LIST PRICE	
30 x 48	EP.3048	\$518	\$570	\$518	60
30 x 54	EP.3054	\$555	\$611	\$555	65
30 x 60	EP.3060	\$616	\$678	\$616	69
30 x 66	EP.3066	\$707	\$778	\$707	75
30 x 72	EP.3072	\$741	\$815	\$741	83
36 x 48	EP.3648	\$592	\$652	\$592	83
36 x 60	EP.3660	\$741	\$815	\$741	83
36 x 66	EP.3666	\$810	\$891	\$810	95
36 x 72	EP.3672	\$888	\$976	\$888	99

### COUNTER CAP TOPS

USE ON PANEL CAPS AS TRANSACTION COUNTER FOR SECRETARIAL AND RECEPTION WORKSTATIONS.

NOTE: ORDER SURFACE WIDTH TO MATCH WIDTH OF PANEL OR PANELS.

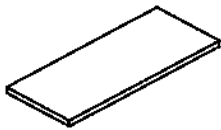

DIMENSION: W X DEPTH	ITEM NUMBER	STD LAMINATE	PREMIUM LAM	xXPHUSION	WEIGHT
		LIST PRICE	LIST PRICE	LIST PRICE	
24 x 14	ECC.2414	\$161	\$177	\$161	14
30 x 14	ECC.3014	\$198	\$217	\$198	18
36 x 14	ECC.3614	\$235	\$259	\$235	21
42 x 14	ECC.4214	\$272	\$299	\$272	25
48 x 14	ECC.4814	\$297	\$327	\$297	28
54 x 14	ECC.5414	\$327	\$359	\$327	32
60 x 14	ECC.6014	\$358	\$394	\$358	35
66 x 14	ECC.6614	\$379	\$417	\$379	38
72 x 14	ECC.7214	\$409	\$450	\$409	42



24 x 24 x 14	ERACC.2424	\$349	\$384	\$349	30
30 x 30 x 14	ERACC.3030	\$475	\$522	\$475	40
36 x 36 x 14	ERACC.3636	\$613	\$675	\$613	45
42 x 42 x 14	ERACC.4242	\$810	\$891	\$810	55
48 x 48 x 14	ERACC.4848	\$897	\$987	\$897	65

### HALF ROUND WORKSURFACE TOP

WORKSURFACE IS DESIGNED TO PROVIDE A COMMON WORK AREA FOR ADJACENT WORKERS BY BRIDGING TWO WORK SURFACES AT THE END OF A PANEL RUN. NOTE: CUTOUT IS TRIMMED IN BLACK ONLY.

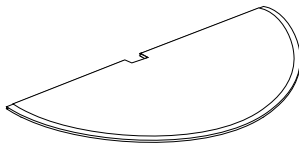

DIAMETER	ITEM NUMBER	STD LAMINATE	PREMIUM LAM	xXPHUSION	WEIGHT
		LIST PRICE	LIST PRICE	LIST PRICE	
50" X 24"D	ED.5024	\$680	\$748	\$680	42

### QUARTER ROUND WORKSURFACE TOP

WORKSURFACE IS DESIGNED TO PROVIDE A COMMON WORK AREA FOR ADJACENT WORKERS BY BRIDGING TWO WORK SURFACES AT THE CORNER OF A PANEL RUN.



DIAMETER	ITEM NUMBER	STD LAMINATE	PREMIUM LAM	xXPHUSION	WEIGHT
		LIST PRICE	LIST PRICE	LIST PRICE	
24 x 24	EWSQ.24	\$692	\$761	\$692	42
30 x 30	EWSQ.30	\$744	\$818	\$744	55







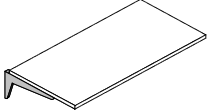
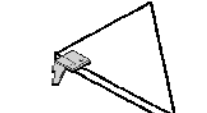
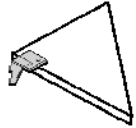
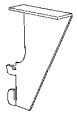

## A2 WORK SURFACE SUPPORTS

**Specify:**

- \* Product number.
- \* Product color - "YY" (BU, DT, HT, LG, LT, MT)

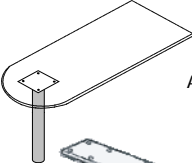
**Note:**

- \* Counter Cap Supports and Corner Work Surface Brackets come in Black only.

ITEM DESCRIPTION	ITEM NUMBER	LIST PRICE	WEIGHT	
	SUPPORT ARM - SHARED 24"D	WSA.24SYY	\$68	5
	SUPPORT ARM - PAIR 24"D	WSA.24YY	\$68	6
	SUPPORT ARM - SHARED 30"D	WSA.30SYY	\$98	5
	SUPPORT ARM - PAIR 30"D	WSA.30YY	\$98	8
	CORNER W. S. BRACKET - PAIR	WSCB.01BK	\$21	1
	COUNTER CAP SUPPORT - PAIR (Available Black Only, 2 pair required per counter cap)	CCS.01BK	\$50	1
<b>COUNTER CAP SUPPORT OEM STYLE, note these require a rod, end cap or connector to install</b>				
	CENTER STYLE For Rod	HMCCCT	\$74	3
	END STYLE for End Cap	HMCCEND	\$74	3
	MID END STYLE for Connector	HMCCMID	\$74	3
	ADJUSTABLE PENINSULA LEG 4"	PLA.YY	\$304	10
	DOUBLE PENINSULA LEG	PLD.YY	\$340	18
	SINGLE SUPPORT LEG 2"	HMALG.YY	\$247	12
	C SUPPORT LEG	PLC.YY	\$354	23
	FLAT PLATE	FP.25BK	\$11	1

## A2 WORK SURFACE SUPPORTS

### WORK SURFACE SUPPORT PANEL END

PANEL END HAS LAMINATE SURFACE AND ATTACHES TO BOTH A PANEL AND WORK SURFACE AT THE END OF A PANEL RUN TO PROVIDE SUPPORT AND ELIMINATE THE NEED FOR A RETURN PANEL AND CONNECTOR.

**Specify:**

- \* Product number.
- \* Support Panel depth to match work surface depth.
- \* Laminate finishes (Pg. 7)

**Note:**

- \* Support Panel is non-handed. Boring is not included, installer must tap and bore part in field for application.
- \* Includes attachment hardware (2 90 degree angle brackets, rear panel bracket and screws) and 2" adjustable glides.
- \* Height is 28".

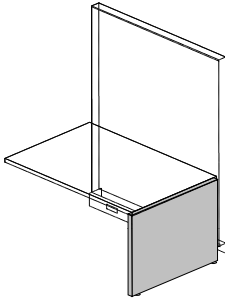

DIMENSION: DEPTH	ITEM NUMBER	STD LAMINATE	PREMIUM LAM	xXPHUSION	WEIGHT
		LIST PRICE	LIST PRICE	LIST PRICE	
18"	HMEWSSP.18	\$357	\$393	\$357	19
24"	HMEWSSP.24	\$368	\$405	\$368	20
30"	HMEWSSP.30	\$479	\$527	\$479	27
36"	HMEWSSP.36	\$551	\$607	\$551	40

### WORK SURFACE SUPPORT

SUPPORT END HAS LAMINATE SURFACE AND ATTACHES TO MODESTY PANEL AND WORK SURFACE. TO CREATE A FREESTANDING OR CANTELIEVER APPLICATION.

**Specify:**

- \* Product number.
- \* Support Panel finished on top and both sides
- \* Laminate finishes (Pg. 7)

**Note:**

- \* Support Panel is non-handed. Boring is not included, installer must tap and bore part in field for application.
- \* Includes attachment hardware for modesty panel (4 90 degree angle brackets and screws) and 2" adjustable glides.
- \* Height is 28".

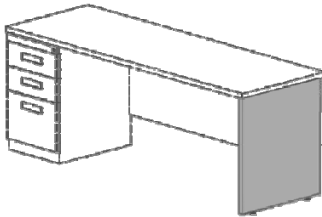

DIMENSION: DEPTH	ITEM NUMBER	STD LAMINATE	PREMIUM LAM	xXPHUSION	WEIGHT
		LIST PRICE	LIST PRICE	LIST PRICE	
18"	HMEWSEP.18	\$357	\$393	\$357	19
24"	HMEWSEP.24	\$368	\$405	\$368	20
30"	HMEWSEP.30	\$479	\$527	\$479	27
36"	HMEWSEP.36	\$551	\$607	\$551	40

## A2 MODESTY PANELS

### MODESTY PANELS

STEEL MODESTY PANEL FOR USE IN APPLICATIONS SIMILAR TO WHAT IS SHOWN.

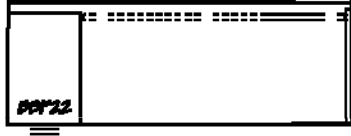

#### Application: End Support Panel to Pedestal

48" Length Top	Use HMEMP.312522.YY
54" Length Top	Use HMEMP.372522.YY
60" Length Top	Use HMEMP.432522.YY
66" Length Top	Use HMEMP.492522.YY
72" Length Top	Use HMEMP.552522.YY

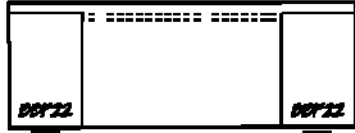

#### Application: Pedestal to Pedestal

60" Length Top	Use HMEMP.292522.YY
66" Length Top	Use HMEMP.352522.YY
72" Length Top	Use HMEMP.412522.YY



#### Application: Peninsula Leg to Pedestal

60" Length Top	Use HMEMP.292522.YY
66" Length Top	Use HMEMP.352522.YY
72" Length Top	Use HMEMP.412522.YY



#### Application: Peninsula Leg to Support Panel

60" Length Top	Use HMEMP.432522.YY
66" Length Top	Use HMEMP.492522.YY
72" Length Top	Use HMEMP.552522.YY

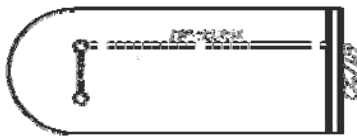

#### Application: Peninsula Leg to Panel

60" Length Top	Use HMEMP.432522.YY
66" Length Top	Use HMEMP.492522.YY
72" Length Top	Use HMEMP.552522.YY



#### Application: Pedestal to Panel

60" Length Top	Use HMEMP.452522.YY
66" Length Top	Use HMEMP.512522.YY
72" Length Top	Use HMEMP.572522.YY

#### Specify:

- \* Product number.
- \* Product color - "YY" (BU, DT, HT, LG, LT, MT)

#### Note:

- \* Modesty Panel includes mounting screws (12 each), pedestals, must be field bored for application.

ITEM DESCRIPTION	ITEM NUMBER	LIST PRICE	WEIGHT
29.25" Modesty Panel 22" High	HMEMP.292522.YY	\$690	20
31.25" Modesty Panel 22" High	HMEMP.312522.YY	\$695	25
35.25" Modesty Panel 22" High	HMEMP.352522.YY	\$706	35
37.25" Modesty Panel 22" High	HMEMP.372522.YY	\$736	40
41.25" Modesty Panel 22" High	HMEMP.412522.YY	\$752	45
43.25" Modesty Panel 22" High	HMEMP.432522.YY	\$762	50
45.25" Modesty Panel 22" High	HMEMP.452522.YY	\$762	52
49.25" Modesty Panel 22" High	HMEMP.492522.YY	\$793	55
51.25" Modesty Panel 22" High	HMEMP.512522.YY	\$798	58
55.25" Modesty Panel 22" High	HMEMP.552522.YY	\$824	60
57.25" Modesty Panel 22" High	HMEMP.572522.YY	\$839	654

## A2 WORK SURFACES WITH SUPPORT HARDWARE

### Specify:

- \* Product number.
- \* Edge finishes (BU, DT, HT, LG, LT, MT), xXphusion edges are wrap with laminate
- \* Laminate finishes (Pg. 7)
- \* Special laminate colors available upon request.
- \* Support Arm finishes (BU, DT, HT, LG, LT, MT)

### Note:

- \* Includes:
- \* 1 pair support arms up to 48"w, 1.5 pair support arms 54" and wider.
- \* Corner worksurfaces also include rear corner bracket
- \* Corner worksurfaces also include black grommet

### RECTANGULAR WORK SURFACES

CAN BE SUPPORTED BY PANELS OR WALL HANGER STRIPS.

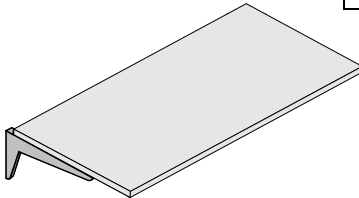

DIMENSION: L x Depth	ITEM NUMBER	STD LAMINATE	PREMIUM LAM	xXPHUSION	WEIGHT
		LIST PRICE	LIST PRICE	LIST PRICE	
24 x 24	HMEWS.2424	\$288	\$317	\$288	30
30 x 24	HMEWS.3024	\$356	\$392	\$356	35
36 x 24	HMEWS.3624	\$361	\$397	\$361	40
42 x 24	HMEWS.4224	\$433	\$476	\$433	45
48 x 24	HMEWS.4824	\$448	\$493	\$448	50
54 x 24	HMEWS.5424	\$539	\$593	\$539	55
60 x 24	HMEWS.6024	\$571	\$628	\$571	60
66 x 24	HMEWS.6624	\$608	\$668	\$608	70
72 x 24	HMEWS.7224	\$626	\$689	\$626	75
78 x 24	HMEWS.7824	\$770	\$847	\$770	85
84 x 24	HMEWS.8424	\$781	\$859	\$781	85
90 x 24	HMEWS.9024	\$880	\$968	\$880	95
96 x 24	HMEWS.9624	\$898	\$988	\$898	105
24 x 30	HMEWS.2430	\$383	\$421	\$383	40
30 x 30	HMEWS.3030	\$425	\$468	\$425	45
36 x 30	HMEWS.3630	\$480	\$528	\$480	50
42 x 30	HMEWS.4230	\$522	\$575	\$522	55
48 x 30	HMEWS.4830	\$535	\$588	\$535	60
54 x 30	HMEWS.5430	\$629	\$692	\$629	70
60 x 30	HMEWS.6030	\$683	\$751	\$683	75
66 x 30	HMEWS.6630	\$742	\$816	\$742	85
72 x 30	HMEWS.7230	\$804	\$885	\$804	90
78 x 30	HMEWS.7830	\$870	\$958	\$870	95
84 x 30	HMEWS.8430	\$881	\$969	\$881	105
90 x 30	HMEWS.9030	\$987	\$1,086	\$987	115
96 x 30	HMEWS.9630	\$997	\$1,097	\$997	125

### CORNER WORKSURFACE

USE FOR 90 DEGREE CORNERS. CORNER BRACKETS INCLUDED. GRAIN DIRECTION 45 DEGREE EXCEPT ON xXPHUSION TOPS THEY ARE 90 DEGREE

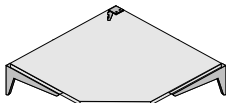

36 x 24  
36 x 30  
42 x 30

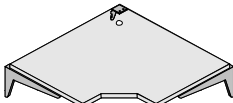

42 x 24  
48 x 24  
48 x 30

DIMENSION: W x DEPTH	ITEM NUMBER	STD LAMINATE	PREMIUM LAM	xXPHUSION	WEIGHT
		LIST PRICE	LIST PRICE	LIST PRICE	
36 x 24	HMECWS.3624	\$620	\$682	\$620	55
42 x 24	HMECWS.4224	\$694	\$764	\$694	65
48 x 24	HMECWS.4824	\$712	\$783	\$712	80
36 x 30	HMECWS.3630	\$652	\$717	\$652	60
42 x 30	HMECWS.4230	\$735	\$809	\$735	70
48 x 30	HMECWS.4830	\$781	\$859	\$781	85

### CORNER WORKSURFACE, INSIDE CURVE

USE FOR 90 DEGREE CORNERS. CORNER BRACKETS INCLUDED. GRAIN DIRECTION 90 DEGREE

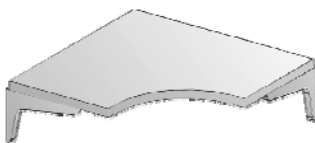

DIMENSION: W x DEPTH	ITEM NUMBER	STD LAMINATE	PREMIUM LAM	xXPHUSION	WEIGHT
		LIST PRICE	LIST PRICE	LIST PRICE	
36 x 24	HMECCWS.3624	\$610	\$682	\$610	55
42 x 24	HMECCWS.4224	\$680	\$763	\$680	65
48 x 24	HMECCWS.4824	\$695	\$805	\$695	80
36 x 30	HMECCWS.3630	\$633	\$697	\$633	60
42 x 30	HMECCWS.4230	\$711	\$782	\$711	70
48 x 30	HMECCWS.4830	\$752	\$827	\$752	85

## A2 WORK SURFACES WITH SUPPORT HARDWARE

### Specify:

- \* Product number.
- \* Edge finishes (BU, DT, HT, LG, LT, MT), xXphusion edges are wrap with laminate
- \* Laminate finishes (Pg. 7)
- \* Special laminate colors available upon request.
- \* Support Arm finishes (BU, DT, HT, LG, LT, MT)

### Note:

- \* Includes:
- \* 1 pair support arms up to 48" w, 1.5 pair support arms 54" and wider.
- \* Corner worksurfaces also include rear corner bracket
- \* Corner worksurfaces also include black grommet

### EXTENDED CORNER WORKSURFACE

USE FOR 90 DEGREE CORNERS. CORNER BRACKETS INCLUDED. GRAIN DIRECTION 90 DEGREE PARALELL TO LONGEST EDGE

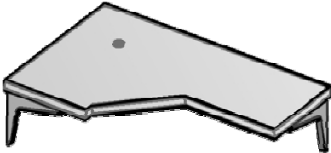
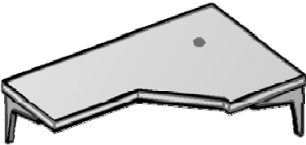
DIMENSION: W x DEPTH	ITEM NUMBER	STD LAMINATE	PREMIUM LAM	xXPHUSION	WEIGHT
		LIST PRICE	LIST PRICE	LIST PRICE	
<b>Right Hand Extension</b>					
	24Dx36Wx48W HMECWS.24364824	\$908	\$999	\$908	85
	24Dx36Wx60W HMECWS.24366024	\$917	\$1,008	\$917	90
	24Dx36Wx66W HMECWS.24366624	\$976	\$1,074	\$976	110
	24Dx36Wx72W HMECWS.24367224	\$981	\$1,078	\$981	115
	24Dx42Wx48W HMECWS.24424824	\$983	\$1,080	\$983	95
	24Dx42Wx60W HMECWS.24426024	\$987	\$1,086	\$987	105
	24Dx42Wx66W HMECWS.24426624	\$989	\$1,088	\$989	115
	24Dx42Wx72W HMECWS.24427224	\$1,051	\$1,156	\$1,051	125
	24Dx48Wx60W HMECWS.24486024	\$1,000	\$1,100	\$1,000	100
	24Dx48Wx66W HMECWS.24486624	\$1,004	\$1,105	\$1,004	120
	24Dx48Wx72W HMECWS.24487224	\$1,051	\$1,156	\$1,051	130
	30Dx42Wx60W HMECWS.30426030	\$1,119	\$1,231	\$1,119	115
	30Dx42Wx66W HMECWS.30426630	\$1,123	\$1,235	\$1,123	125
	30Dx42Wx72W HMECWS.30427230	\$1,161	\$1,277	\$1,161	135
	30Dx48Wx60W HMECWS.30486030	\$1,164	\$1,280	\$1,164	120
30Dx48Wx66W HMECWS.30486630	\$1,169	\$1,286	\$1,169	130	
30Dx48Wx72W HMECWS.30487230	\$1,174	\$1,292	\$1,174	140	
<b>Left Hand Extension</b>					
	24Dx48Wx36W HMECWS.24483624	\$908	\$999	\$908	85
	24Dx60Wx36W HMECWS.24603624	\$917	\$1,008	\$917	90
	24Dx66Wx36W HMECWS.24663624	\$976	\$1,074	\$976	110
	24Dx72Wx36W HMECWS.24723624	\$981	\$1,078	\$981	115
	24Dx48Wx42W HMECWS.24484224	\$983	\$1,080	\$983	95
	24Dx60Wx42W HMECWS.24604224	\$987	\$1,086	\$987	105
	24Dx66Wx42W HMECWS.24664224	\$989	\$1,088	\$989	115
	24Dx72Wx42W HMECWS.24724224	\$1,051	\$1,156	\$1,051	125
	24Dx60Wx48W HMECWS.24604824	\$1,000	\$1,100	\$1,000	100
	24Dx66Wx48W HMECWS.24664824	\$1,004	\$1,105	\$1,004	120
	24Dx72Wx48W HMECWS.24724824	\$1,051	\$1,156	\$1,051	130
	30Dx60Wx42W HMECWS.30604230	\$1,119	\$1,231	\$1,119	115
	30Dx66Wx42W HMECWS.30664230	\$1,123	\$1,235	\$1,123	125
	30Dx72Wx42W HMECWS.30724230	\$1,161	\$1,277	\$1,161	135
	30Dx60Wx48W HMECWS.30604830	\$1,164	\$1,280	\$1,164	120
30Dx66Wx48W HMECWS.30664830	\$1,169	\$1,286	\$1,169	130	
30Dx72Wx48W HMECWS.30724830	\$1,174	\$1,292	\$1,174	140	

## A2 WORK SURFACES WITH SUPPORT HARDWARE

### Specify:

- \* Product number.
- \* Edge finishes (BU, DT, HT, LG, LT, MT), xXphusion edges are wrap with laminate
- \* Laminate finishes (Pg. 7)
- \* Special laminate colors available upon request.
- \* Support Arm finishes (BU, DT, HT, LG, LT, MT)

### Note:

- \* Includes:
- \* 1 pair support arms up to 48"W, 1.5 pair support arms 54" and wider.
- \* Corner worksurfaces also include rear corner bracket
- \* Corner worksurfaces also include black grommet

### EXTENDED INSIDE CURVE CORNER WORKSURFACE

USE FOR 90 DEGREE CORNERS. CORNER BRACKETS INCLUDED. GRAIN DIRECTION 90 DEGREE PARALELL TO LONGEST EDGE

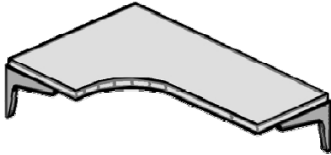
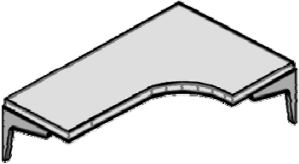
DIMENSION: W x DEPTH	ITEM NUMBER	STD LAMINATE	PREMIUM LAM	xXPUSION	WEIGHT
		LIST PRICE	LIST PRICE	LIST PRICE	
<b>Right Hand Extension</b>					
	24Dx36Wx48W HMECCWS.24364824	\$908	\$999	\$908	85
	24Dx36Wx60W HMECCWS.24366024	\$917	\$1,008	\$917	90
	24Dx36Wx66W HMECCWS.24366624	\$976	\$1,074	\$976	110
	24Dx36Wx72W HMECCWS.24367224	\$981	\$1,078	\$981	115
	24Dx42Wx48W HMECCWS.24424824	\$983	\$1,080	\$983	95
	24Dx42Wx60W HMECCWS.24426024	\$987	\$1,086	\$987	105
	24Dx42Wx66W HMECCWS.24426624	\$989	\$1,088	\$989	115
	24Dx42Wx72W HMECCWS.24427224	\$1,051	\$1,156	\$1,051	125
	24Dx48Wx60W HMECCWS.24486024	\$1,000	\$1,100	\$1,000	100
	24Dx48Wx66W HMECCWS.24486624	\$1,004	\$1,105	\$1,004	120
	24Dx48Wx72W HMECCWS.24487224	\$1,051	\$1,156	\$1,051	130
	30Dx42Wx60W HMECCWS.30426030	\$1,119	\$1,231	\$1,119	115
30Dx42Wx66W HMECCWS.30426630	\$1,123	\$1,235	\$1,123	125	
30Dx42Wx72W HMECCWS.30427230	\$1,161	\$1,277	\$1,161	135	
30Dx48Wx60W HMECCWS.30486030	\$1,164	\$1,280	\$1,164	120	
30Dx48Wx66W HMECCWS.30486630	\$1,169	\$1,286	\$1,169	130	
30Dx48Wx72W HMECCWS.30487230	\$1,174	\$1,292	\$1,174	140	
<b>Left Hand Extension</b>					
	24Dx48Wx36W HMECCWS.24483624	\$908	\$999	\$908	85
	24Dx60Wx36W HMECCWS.24603624	\$917	\$1,008	\$917	90
	24Dx66Wx36W HMECCWS.24663624	\$976	\$1,074	\$976	110
	24Dx72Wx36W HMECCWS.24723624	\$981	\$1,078	\$981	115
	24Dx48Wx42W HMECCWS.24484224	\$983	\$1,080	\$983	95
	24Dx60Wx42W HMECCWS.24604224	\$987	\$1,086	\$987	105
	24Dx66Wx42W HMECCWS.24664224	\$989	\$1,088	\$989	115
	24Dx72Wx42W HMECCWS.24724224	\$1,051	\$1,156	\$1,051	125
	24Dx60Wx48W HMECCWS.24604824	\$1,000	\$1,100	\$1,000	100
	24Dx66Wx48W HMECCWS.24664824	\$1,004	\$1,105	\$1,004	120
	24Dx72Wx48W HMECCWS.24724824	\$1,051	\$1,156	\$1,051	130
	30Dx60Wx42W HMECCWS.30604230	\$1,119	\$1,231	\$1,119	115
30Dx66Wx42W HMECCWS.30664230	\$1,123	\$1,235	\$1,123	125	
30Dx72Wx42W HMECCWS.30724230	\$1,161	\$1,277	\$1,161	135	
30Dx60Wx48W HMECCWS.30604830	\$1,164	\$1,280	\$1,164	120	
30Dx66Wx48W HMECCWS.30664830	\$1,169	\$1,286	\$1,169	130	
30Dx72Wx48W HMECCWS.30724830	\$1,174	\$1,292	\$1,174	140	

## A2 WORK SURFACES WITH SUPPORT HARDWARE

### Specify:

- \* Product number.
- \* Edge finishes (BU, DT, HT, LG, LT, MT), xXphusion edges are wrap with laminate
- \* Laminate finishes (Pg. 7)
- \* Special laminate colors available upon request.
- \* Support Arm finishes (BU, DT, HT, LG, LT, MT)
- \* Peninsula Leg finishes (BU, DT, HT, LG, LT, MT)

### Note:

- \* Includes:
- \* Peninsula Top includes 1 pair support arms.
- \* Peninsula Top includes 1 Single Column Peninsula Base 4" Diameter
- \* Counter Caps include standard universal mounting brackets.

### PENINSULA WORK SURFACE

CAN BE SUPPORTED BY PANELS OR WALL HANGER STRIPS. 4" ADJUSTABLE PENINSULA LEG INCLUDED.

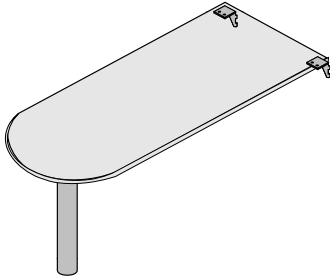

DIMENSION: W x DEPTH	ITEM NUMBER	STD LAMINATE	PREMIUM LAM	xXPHUSION	WEIGHT
		LIST PRICE	LIST PRICE	LIST PRICE	
24 x 48	HMEP.2448	\$778	\$856	\$778	85
24 x 60	HMEP.2460	\$902	\$993	\$902	88
30 x 48	HMEP.3048	\$898	\$988	\$898	90
30 x 54	HMEP.3054	\$934	\$1,028	\$934	93
30 x 60	HMEP.3060	\$995	\$1,095	\$995	95
30 x 66	HMEP.3066	\$1,004	\$1,105	\$1,004	97
30 x 72	HMEP.3072	\$1,018	\$1,120	\$1,018	98
36 x 48	HMEP.3648	\$897	\$987	\$897	92
36 x 60	HMEP.3660	\$1,017	\$1,119	\$1,017	105
36 x 66	HMEP.3666	\$1,086	\$1,194	\$1,086	108
36 x 72	HMEP.3672	\$1,182	\$1,301	\$1,182	110

### COUNTER CAP

USE ON PANEL CAPS AS TRANSACTION COUNTER FOR SECRETARIAL AND RECEPTION WORKSTATIONS.

NOTE: ORDER SURFACE WIDTH TO MATCH WIDTH OF PANEL OR PANELS.

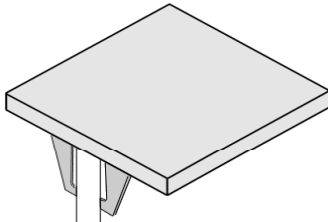

DIMENSION: W X DEPTH	ITEM NUMBER				WEIGHT
24 x 14	HMECC.2414	\$259	\$284	\$259	19
30 x 14	HMECC.3014	\$271	\$298	\$271	22
36 x 14	HMECC.3614	\$282	\$310	\$282	30
42 x 14	HMECC.4214	\$289	\$318	\$289	40
48 x 14	HMECC.4814	\$296	\$325	\$296	43
54 x 14	HMECC.5414	\$321	\$353	\$321	50
60 x 14	HMECC.6014	\$359	\$396	\$359	55
66 x 14	HMECC.6614	\$380	\$418	\$380	60
72 x 14	HMECC.7214	\$409	\$450	\$409	65
78 x 14	HMECC.7814	\$553	\$609	\$553	70
84 x 14	HMECC.8414	\$564	\$621	\$564	75
90 x 14	HMECC.9014	\$571	\$627	\$571	80
96 x 14	HMECC.9614	\$578	\$636	\$578	85
24 x 24 x 14	HMERACC.2424	\$447	\$491	\$447	20
30 x 30 x 14	HMERACC.3030	\$541	\$595	\$541	35
36 x 36 x 14	HMERACC.3636	\$715	\$786	\$715	40
42 x 42 x 14	HMERACC.4242	\$721	\$793	\$721	50
48 x 48 x 14	HMERACC.4848	\$732	\$805	\$732	554

## A2 WORK SURFACES & TABLES WITH SUPPORT HARDWARE

### Specify:

- \* Product number.
- \* Size of Table.
- \* Edge finishes (BU, DT, HT, LG, LT, MT), xXphusion edges are wrap with laminate
- \* Laminate finishes (Pg. 7)
- \* Special laminate colors available upon request.
- \* Post & Leg finishes (BU, DT, HT, LG, LT, MT)

### Note:

- \* Includes laminate top with vinyl t-edge.
- \* Cutout is trimmed in Black only.
- \* Height is 29"
- \* Thickness is 1.25"

### HALF ROUND WORKSURFACE WITH SUPPORTS

INCLUDES CHOICE OF SUPPORTING HARDWARE TO CREATE EITHER A STATIONARY SURFACE OR ISLAND. TWO HALF ROUND UNITS (HMEDB OR HMEDC) CAN BE JOINED TO CREATE A MEETING TABLE. ORDER FLAT PLATE (PG. 36) SEPARATELY.

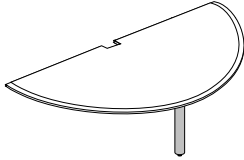

Includes One Post Leg  
HMEDA.5024

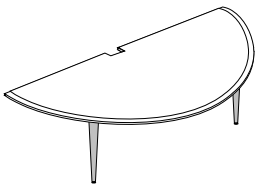

Includes Two Cone Legs with Glides  
HMEDB.5024

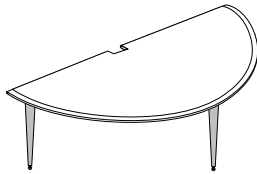

Includes Three Cone legs with  
Casters for mobile use  
HMEDC.5024

DIMENSION L X W	ITEM NUMBER	STD LAMINATE	PREMIUM LAM	xXPHUSION	WEIGHT
		LIST PRICE	LIST PRICE	LIST PRICE	
50" X 24"	HMEDA.5024	\$846	\$930	\$846	52
50" X 24"	HMEDB.5024	\$1,026	\$1,129	\$1,026	57
50" X 24"	HMEDC.5024	\$1,452	\$1,598	\$1,452	66

### QUARTER ROUND WORKSURFACE WITH SUPPORTS

INCLUDES SUPPORTING HARDWARE TO CONNECT TO WORKSURFACES AND PANELS ON EACH SIDE

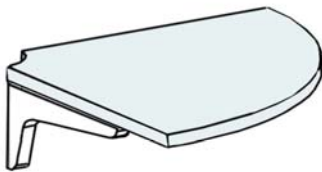

DIMENSION L X W	ITEM NUMBER	STD LAMINATE	PREMIUM LAM	xXPHUSION	WEIGHT
		LIST PRICE	LIST PRICE	LIST PRICE	
24 x 24	HMEWSQ.24yy	\$864	\$951	\$864	49
30 x 30	HMEWSQ.30yy	\$904	\$995	\$863	64

## A2 TABLES

### Specify:

- \* Product number.
- \* Size of Table.
- \* Edge finishes (BU, DT, HT, LG, LT, MT), xXphusion edges are wrap with laminate
- \* Laminate finishes (Pg. 7)
- \* Special laminate colors available upon request.
- \* Round Table Base finishes (BU, DT, HT, LG, LT, MT)
- \* Training Table Base finish is Black only.

### Note:

- \* Tables include laminate top with 3mm vinyl edge.
- \* Height is 29"
- \* Thickness is 1.25"
- \* Includes 2" tubular base

## ROUND MEETING TABLES

INCLUDES A 2" DIAMETER ROUND TUBE BASE.

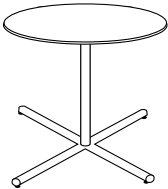

DIAMETER	ITEM NUMBER	STD LAMINATE	PREMIUM LAM	xXPHUSION	WEIGHT
		LIST PRICE	LIST PRICE	LIST PRICE	
30"	HMERT.30	\$719	\$791	\$719	36
36"	HMERT.36	\$798	\$879	\$798	50
42"	HMERT.42	\$898	\$988	\$898	69
48"	HMERT.48	\$998	\$1,098	\$998	83

## TRAINING TABLES

INCLUDES A MODESTY PANEL AND "C" LEGS WITH CABLE ACCESS PANELS.

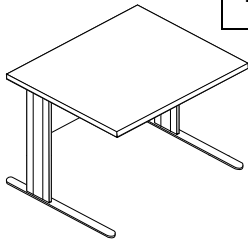

DIMENSION L X W	ITEM NUMBER				WEIGHT
24 x 36"	HMETT.2436	\$671	\$737	\$671	73
24 x 42"	HMETT.2442	\$727	\$800	\$727	82
24 x 48"	HMETT.2448	\$748	\$823	\$748	88
24 x 54"	HMETT.2454	\$825	\$907	\$825	100
24 x 60"	HMETT.2460	\$856	\$941	\$856	109
24 x 66"	HMETT.2466	\$904	\$995	\$904	115
24 x 72"	HMETT.2472	\$943	\$1,038	\$943	124
30 x 36"	HMETT.3036	\$703	\$774	\$703	73
30 x 42"	HMETT.3042	\$759	\$835	\$759	82
30 x 48"	HMETT.3048	\$780	\$858	\$780	88
30 x 54"	HMETT.3054	\$858	\$943	\$858	100
30 x 60"	HMETT.3060	\$888	\$976	\$888	109
30 x 66"	HMETT.3066	\$936	\$1,030	\$936	115
30 x 72"	HMETT.3072	\$975	\$1,073	\$975	1244

## A2 OVERHEAD STORAGE

### Specify:

- \* Product number.
- \* Product color – "YY" (BU, DT, HT, LG, LT, MT)
- \* Fabric style & color number.
- \* Shelf End color, if different from Shelf and top of Un

### Note:

- \* Flipper Door is lockable.
- \* Locks can be keyed alike upon request.
- \* Shipped partially assembled.
- \* Fabric yardage estimate is for directional application (minimum 66" usable width).
- \* Special fabrics may affect yardage requirements.

### FLIPPER DOOR UNIT, FABRIC

INCLUDES SHELF, HIGH SHELF ENDS, AND FLIPPER DOOR COVERED IN FABRIC.

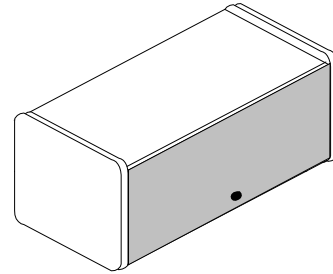

DIMENSION: W x D x H	ITEM NUMBER	FABRIC Q COM LIST	FABRIC GRADE 1 LIST	FABRIC GRADE 2 LIST	FABRIC GRADE 3 LIST	FABRIC GRADE 4 LIST	YDG REQ'D	WEIGHT
24 x 12.5 x 15.5	HMEFDU.24YY	\$438	\$446	\$466	\$483	\$507	0.67	41
30 x 12.5 x 15.5	HMEFDU.30YY	\$451	\$455	\$475	\$492	\$517	0.67	45
36 x 12.5 x 15.5	HMEFDU.36YY	\$462	\$471	\$490	\$508	\$534	0.67	50
42 x 12.5 x 15.5	HMEFDU.42YY	\$484	\$489	\$502	\$519	\$545	0.67	53
48 x 12.5 x 15.5	HMEFDU.48YY	\$514	\$520	\$530	\$548	\$576	0.67	55
60 x 12.5 x 15.5	HMEFDU.60YY	\$615	\$621	\$641	\$658	\$691	0.67	64

### FLIPPER DOOR, FABRIC

ORDER HIGH SHELF (Pg. 50) TO FORM COMPLETE FLIPPER UNIT.

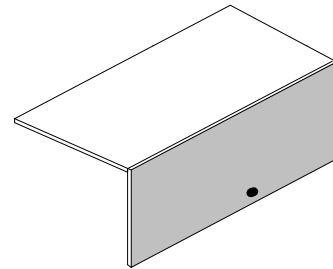

DIMENSION: W x D	ITEM NUMBER	FABRIC Q COM LIST	FABRIC GRADE 1 LIST	FABRIC GRADE 2 LIST	FABRIC GRADE 3 LIST	FABRIC GRADE 4 LIST	YDG REQ'D	WEIGHT
24 x 12.5	HMEFD.24YY	\$272	\$277	\$297	\$314	\$330	0.67	20
30 x 12.5	HMEFD.30YY	\$276	\$281	\$301	\$318	\$335	0.67	22
36 x 12.5	HMEFD.36YY	\$281	\$288	\$308	\$325	\$342	0.67	23
42 x 12.5	HMEFD.42YY	\$285	\$290	\$310	\$328	\$344	0.67	24
48 x 12.5	HMEFD.48YY	\$299	\$309	\$318	\$338	\$353	0.67	25
60 x 12.5	HMEFD.60YY	\$387	\$394	\$414	\$432	\$453	0.67	28

### KEY ALIKE OPTION FOR PEDESTALS/FILES/CABINETS/FLIPPER DOORS.

ITEM DESCRIPTION	ITEM NUMBER	LIST PRICE	WEIGHT
Key Alike	HMKA	\$19	1

## A2 OVERHEAD STORAGE

**Specify:**

- \* Product number.
- \* Product color – "YY" (BU, DT, HT, LG, LT, MT)
- \* Shelf End color, if different from Shelf.

**Note:**

- \* Includes Shelf and Shelf Ends.
- \* Shipped one per box.
- \* Shipped unassembled.

**HIGH SHELF**

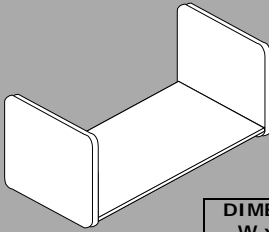

DIMENSION: W x D x H	ITEM NUMBER	LIST PRICE	WEIGHT
24 x 12.5 x 15.5	HMEHS.24YY	\$161	21
30 x 12.5 x 15.5	HMEHS.30YY	\$168	23
36 x 12.5 x 15.5	HMEHS.36YY	\$180	27
42 x 12.5 x 15.5	HMEHS.42YY	\$196	29
48 x 12.5 x 15.5	HMEHS.48YY	\$216	30
60 x 12.5 x 15.5	HMEHS.60YY	\$227	36

**LOW SHELF - 7 1/2 " HIGH**

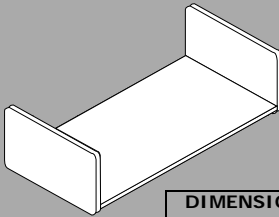

DIMENSION: W x D x H	ITEM NUMBER	WEIGHT
24 x 12.5 x 7.5	HMELS.24YY	20
30 x 12.5 x 7.5	HMELS.30YY	22
36 x 12.5 x 7.5	HMELS.36YY	26
42 x 12.5 x 7.5	HMELS.42YY	28
48 x 12.5 x 7.5	HMELS.48YY	29
60 x 12.5 x 7.5	HMELS.60YY	354

## MIRAGE METAL OVERHEAD STORAGE -STANDARD DEPTH

**Specify:**

- \* Product number.
- \* Product color – “YY” (BU, DT, HT, LG, LT, MT)
- \* Shelf End color, if different from Shelf.

**Note:**

- \* Includes Shelf and Shelf Ends
- \* Shipped one per box.
- \* Shipped unassembled.

### METAL FLIPPER DOOR UNIT WITH LOCK RECEEDING DOOR

INCLUDES SHELF, HIGH SHELF ENDS, AND METAL FLIPPER DOOR.  
DOOR RECEEDS INTO THE CABINET

**Specify:**

- \* Product number.
- \* Product color – “YY” (BU, DT, HT, LG, LT, MT)

**Note:**

- \* Locks can be keyed alike upon request.
- \* Shipped one per box.
- \* Ready to install.
- \* Door recesses into the cabinet.

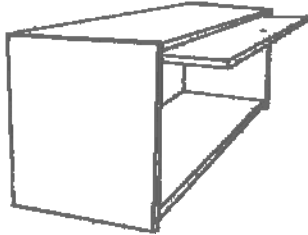

DIMENSION: W x D	ITEM NUMBER	LIST PRICE	WEIGHT
24 x 15 x 14.5	MFRFDU.24YY	\$715	35
30 x 15 x 14.5	MFRFDU.30YY	\$733	38
36 x 15 x 14.5	MFRFDU.36YY	\$759	45
42 x 15 x 14.5	MFRFDU.42YY	\$803	55
48 x 15 x 14.5	MFRFDU.48YY	\$865	61
60 x 15 x 14.5	MFRFDU.60YY	\$1,067	75

### METAL FLIPPER DOOR UNIT WITH LOCK OVERTOP DOOR

INCLUDES SHELF, HIGH SHELF ENDS, AND METAL FLIPPER DOOR.  
DOOR OPENS OVER THE TOP OF THE CABINET

**Specify:**

- \* Product number.
- \* Product color – “YY” (BU, DT, HT, LG, LT, MT)

**Note:**

- \* Locks can be keyed alike upon request.
- \* Shipped one per box.
- \* Ready to install.
- \* Door opens over Flipper top.

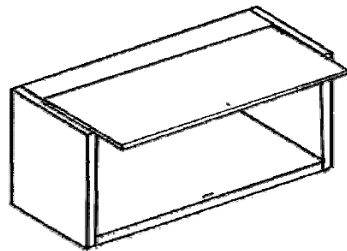

DIMENSION: W x D	ITEM NUMBER	LIST PRICE	WEIGHT
24 x 15 x 13.5	MFFDU.24YY	\$599	30
30 x 15 x 13.5	MFFDU.30YY	\$617	35
36 x 15 x 13.5	MFFDU.36YY	\$634	40
42 x 15 x 13.5	MFFDU.42YY	\$688	45
48 x 15 x 13.5	MFFDU.48YY	\$732	50
60 x 15 x 13.5	MFFDU.60YY	\$900	64

### KEY ALIKE OPTION FOR PEDESTALS/FILES/CABINETS/FLIPPER DOORS.

ITEM DESCRIPTION	ITEM NUMBER	LIST PRICE	WEIGHT
Key Alike	HMKA	\$19	1

## A2 TACKBOARDS

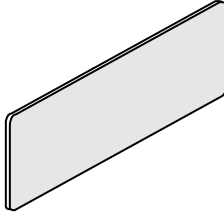

**Specify:**

- \* Product number.
- \* Fabric style and number.

**Note:**

- \* Fabric covered.
- \* Includes all hardware for mounting.
- \* Fabric yardage estimate is for directional application (minimum 66" usable width).
- \* Special fabrics may affect yardage requirements.

DIMENSION: H x W	ITEM NUMBER	FABRIC Q COM LIST	FABRIC GRADE 1 LIST	FABRIC GRADE 2 LIST	FABRIC GRADE 3 LIST	FABRIC GRADE 4 LIST	YDG REQ'D	WEIGHT
12 x 24	HMETB.1224	\$155	\$171	\$184	\$194	\$209	0.50	7
12 x 30	HMETB.1230	\$166	\$183	\$196	\$205	\$221	0.50	8
12 x 36	HMETB.1236	\$174	\$191	\$203	\$212	\$229	0.50	9
12 x 42	HMETB.1242	\$181	\$199	\$211	\$220	\$237	0.50	10
12 x 48	HMETB.1248	\$183	\$201	\$213	\$222	\$239	0.50	11
12 x 60	HMETB.1260	\$193	\$209	\$222	\$232	\$247	0.67	12
16 x 24	HMETB.1624	\$158	\$174	\$187	\$197	\$212	0.67	8
16 x 30	HMETB.1630	\$168	\$184	\$197	\$206	\$222	0.67	9
16 x 36	HMETB.1636	\$178	\$195	\$207	\$216	\$233	0.67	10
16 x 42	HMETB.1642	\$185	\$202	\$214	\$224	\$240	0.67	11
16 x 48	HMETB.1648	\$191	\$207	\$220	\$230	\$245	0.67	12
16 x 60	HMETB.1660	\$198	\$214	\$227	\$237	\$252	0.67	15
24 x 24	HMETB.2424	\$238	\$254	\$267	\$285	\$297	1.50	15
24 x 48	HMETB.2448	\$299	\$309	\$324	\$343	\$354	1.50	22
36 x 36	HMETB.3636	\$351	\$376	\$418	\$446	\$469	1.50	23
48 X 48	HMETB.4848	\$451	\$504	\$522	\$586	\$616	1.50	225

**A1 PRODUCT5**

## A1 FABRIC PANEL - NO RACEWAY

### Product Description

Fabric covered hard surface panel. Includes (1) panel.

**PANEL CONNECTORS MUST BE ORDERED SEPARATELY.**

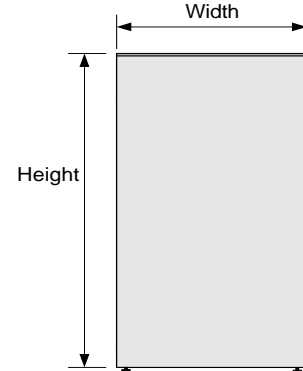
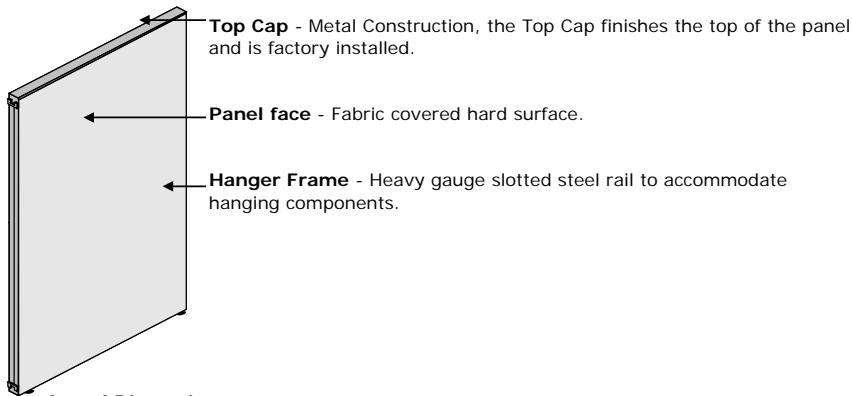

### Actual Dimensions

Depth (Thickness)	2"
Width	12", 18", 24", 30", 36", 42", 48" & 60"
Height (Minimum)	34", 42", 48", 57", 62" & 80"

### Specify:

- \* Product number.
- \* Trim color – "YY" (BU, DT, HT, LG, LT, MT)
- \* Fabric name and style number.

### Note:

- \* Order Finished End (Pg. 67) to finish exposed panel end.
- \* Order Panel Connectors (Pgs. 66-67)
- \* Fabric yardage estimate is for directional application (minimum 66" usable width).
- \* Special fabrics may affect yardage requirements.

DIMENSION: H x W	ITEM NUMBER	FABRIC Q COM LIST	FABRIC GRADE 1 LIST	FABRIC GRADE 2 LIST	FABRIC GRADE 3 LIST	YDG REQ'D	WEIGHT
34 x 12	H3412YY	\$278	\$313	\$350	\$387	1.25	13
34 x 18	H3418YY	\$293	\$328	\$365	\$402	1.25	18
34 x 24	H3424YY	\$298	\$333	\$370	\$407	1.25	22
34 x 30	H3430YY	\$333	\$367	\$433	\$500	2.25	28
34 x 36	H3436YY	\$365	\$398	\$464	\$530	2.25	30
34 x 42	H3442YY	\$394	\$427	\$493	\$560	2.25	31
34 x 48	H3448YY	\$427	\$459	\$525	\$592	2.25	33
34 x 60	H3460YY	\$535	\$563	\$629	\$696	2.25	465

## A1 FABRIC PANEL - NO RACEWAY

**Specify:**

- \* Product number.
- \* Trim color – "YY" (BU, DT, HT, LG, LT, MT)
- \* Fabric name and style number.

**Note:**

- \* Order Finished End (Pg. 67) to finish exposed panel end.
- \* Order Panel Connectors (Pgs. 66-67)
- \* Fabric yardage estimate is for directional application (minimum 66" usable width).
- \* Special fabrics may affect yardage requirements.

DIMENSION: H x W	ITEM NUMBER	FABRIC Q COM LIST	FABRIC GRADE 1 LIST	FABRIC GRADE 2 LIST	FABRIC GRADE 3 LIST	YDG REQ'D	WEIGHT
42 x 12	H4212YY	\$277	\$323	\$364	\$403	1.34	16
42 x 18	H4218YY	\$293	\$338	\$378	\$417	1.34	20
42 x 24	H4224YY	\$298	\$343	\$383	\$422	1.34	27
42 x 30	H4230YY	\$341	\$385	\$464	\$543	2.67	34
42 x 36	H4236YY	\$387	\$431	\$509	\$588	2.67	37
42 x 42	H4242YY	\$433	\$475	\$543	\$632	2.67	38
42 x 48	H4248YY	\$482	\$522	\$600	\$680	2.67	41
42 x 60	H4260YY	\$602	\$640	\$718	\$797	2.67	57
48 x 12	H4812YY	\$286	\$343	\$387	\$432	1.50	20
48 x 18	H4818YY	\$302	\$357	\$402	\$446	1.50	25
48 x 24	H4824YY	\$308	\$365	\$409	\$453	1.50	29
48 x 30	H4830YY	\$359	\$414	\$503	\$591	3.00	36
48 x 36	H4836YY	\$409	\$462	\$551	\$640	3.00	40
48 x 42	H4842YY	\$461	\$513	\$602	\$690	3.00	42
48 x 48	H4848YY	\$513	\$563	\$652	\$741	3.00	45
48 x 60	H4860YY	\$640	\$687	\$776	\$864	3.00	60
62 x 12	H6212YY	\$308	\$365	\$423	\$482	2.00	25
62 x 18	H6218YY	\$370	\$424	\$483	\$579	2.00	32
62 x 24	H6224YY	\$378	\$432	\$490	\$549	2.00	38
62 x 30	H6230YY	\$433	\$486	\$594	\$702	3.80	42
62 x 36	H6236YY	\$486	\$538	\$646	\$754	3.80	49
62 x 42	H6242YY	\$537	\$587	\$695	\$803	3.80	54
62 x 48	H6248YY	\$591	\$640	\$748	\$856	3.80	59
62 x 60	H6260YY	\$739	\$784	\$892	\$1,000	3.80	68
80 x 12	H8012YY	\$319	\$414	\$485	\$555	2.40	28
80 x 18	H8018YY	\$401	\$493	\$564	\$634	2.40	38
80 x 24	H8024YY	\$411	\$504	\$575	\$645	2.40	53
80 x 30	H8030YY	\$473	\$563	\$705	\$847	4.80	56
80 x 36	H8036YY	\$535	\$624	\$765	\$907	4.80	71
80 x 42	H8042YY	\$594	\$682	\$823	\$965	4.80	76
80 x 48	H8048YY	\$655	\$742	\$883	\$1,025	4.80	87
80 x 60	H8060YY	\$771	\$855	\$996	\$1,138	4.80	895

## A1 FABRIC ACOUSTICAL PANEL - NO RACEWAY

### Product Description

Fabric covered sound-reducing panel. Includes (1) panel.

**PANEL CONNECTORS MUST BE ORDERED SEPARATELY.**

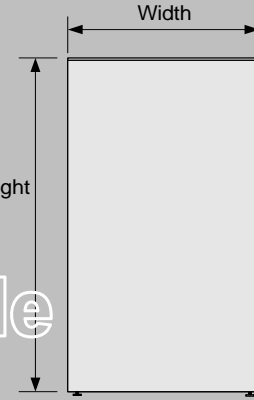

Open Market Only  
Not on GSA Schedule

### Actual Dimensions

Depth (Thickness)	2"
Width	12", 18", 24", 30", 36", 42", 48" & 60"
Height (Minimum)	48", 57", 62" & 80"

### Specify:

- \* Product number.
- \* Trim color - "YY" (BU, DT, HT, LG, LT, MT)
- \* Fabric name and style number.

### Note:

- \* Order Finished End (Pg. 67) to finish exposed panel end.
- \* Order Panel Connectors (Pgs. 66-67)
- \* Fabric yardage estimate is for directional application (minimum 66" usable width).
- \* Special fabrics may affect yardage requirements.5

## A1 FABRIC ACOUSTICAL PANEL - NO RACEWAY

**Specify:**

- \* Product number.
- \* Trim color – "YY" (BU, DT, HT, LG, LT, MT)
- \* Fabric name and style number.

**Note:**

- \* Order Finished End (Pg. 67) to finish exposed panel end.
- \* Order Panel Connectors (Pgs. 66-67)
- \* Fabric yardage estimate is for directional application (minimum 66" usable width).
- \* Special fabrics may affect yardage requirements.

DIMENSION: H x W	ITEM NUMBER	FABRIC Q COM LIST	FABRIC GRADE 1 LIST	FABRIC GRADE 2 LIST	FABRIC GRADE 3 LIST	YDG REQ'D	WEIGHT
48 x 12	HA.4812YY	\$403	\$456	\$500	\$544	1.50	17
48 x 18	HA.4818YY	\$464	\$516	\$560	\$605	1.50	19
48 x 24	HA.4824YY	\$473	\$525	\$569	\$613	1.50	28
48 x 30	HA.4830YY	\$508	\$558	\$647	\$735	3.00	35
48 x 36	HA.4836YY	\$554	\$604	\$692	\$781	3.00	38
48 x 42	HA.4842YY	\$598	\$647	\$736	\$824	3.00	39
48 x 48	HA.4848YY	\$643	\$690	\$779	\$867	3.00	42
48 x 60	HA.4860YY	\$796	\$830	\$913	\$1,007	3.00	58
62 x 12	HA.6212YY	\$433	\$486	\$545	\$605	2.00	26
62 x 18	HA.6218YY	\$466	\$518	\$577	\$636	2.00	28
62 x 24	HA.6224YY	\$477	\$529	\$588	\$647	2.00	39
62 x 30	HA.6230YY	\$522	\$572	\$633	\$688	3.80	43
62 x 36	HA.6236YY	\$568	\$613	\$675	\$734	3.80	50
62 x 42	HA.6242YY	\$615	\$663	\$711	\$879	3.80	55
62 x 48	HA.6248YY	\$663	\$711	\$819	\$927	3.80	60
62 x 60	HA.6260YY	\$805	\$849	\$957	\$1,065	3.80	69
80 x 12	HA.8012YY	\$466	\$557	\$628	\$699	2.40	29
80 x 18	HA.8018YY	\$506	\$596	\$667	\$738	2.40	31
80 x 24	HA.8024YY	\$518	\$608	\$679	\$750	2.40	54
80 x 30	HA.8030YY	\$578	\$666	\$808	\$949	4.80	57
80 x 36	HA.8036YY	\$653	\$739	\$880	\$1,022	4.80	72
80 x 42	HA.8042YY	\$704	\$790	\$931	\$1,072	4.80	77
80 x 48	HA.8048YY	\$756	\$840	\$982	\$1,123	4.80	88
80 x 60	HA.8060YY	\$869	\$950	\$1,092	\$1,233	4.80	90

Open Market Only  
Not on GSA Schedule

## A1 FABRIC TACKABLE ACOUSTICAL PANEL - NO RACEWAY

### Product Description

Fabric covered tackable sound-reducing panel. Includes (1) panel.

**PANEL CONNECTORS MUST BE ORDERED SEPARATELY.**

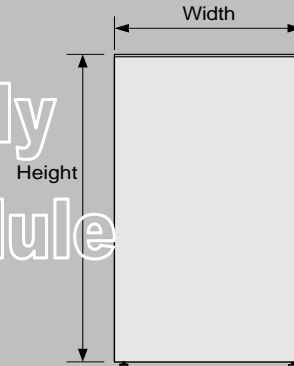

### Actual Dimensions

Depth (Thickness)	2"
Width	12", 18", 24", 30", 36", 42", 48" & 60"
Height (Minimum)	48", 57", 62" & 80"

### Specify:

- \* Product number.
- \* Trim color - "YY" (BU, DT, HT, LG, LT, MT)
- \* Fabric name and style number.

### Note:

- \* Order Finished End (Pg. 67) to finish exposed panel end.
- \* Order Panel Connectors (Pgs. 66-67)
- \* Fabric yardage estimate is for directional application (minimum 66" usable width).
- \* Special fabrics may affect yardage requirements.5

Open Market Only  
Not on GSA Schedule

## A1 FABRIC TACKABLE ACOUSTICAL PANEL - NO RACEWAY

**Specify:**

- \* Product number.
- \* Trim color – "YY" (BU, DT, HT, LG, LT, MT)
- \* Fabric name and style number.

**Note:**

- \* Order Finished End (Pg. 67) to finish exposed panel end.
- \* Order Panel Connectors (Pgs. 66-67)
- \* Fabric yardage estimate is for directional application (minimum 66" usable width).
- \* Special fabrics may affect yardage requirements.

DIMENSION: H x W	ITEM NUMBER	FABRIC Q COM LIST	FABRIC GRADE 1 LIST	FABRIC GRADE 2 LIST	FABRIC GRADE 3 LIST	YDG REQ'D	WEIGHT
48 x 12	HT4812YY	\$371	\$401	\$445	\$490	1.50	27
48 x 18	HT4818YY	\$386	\$430	\$474	\$518	1.50	29
48 x 24	HT4824YY	\$400	\$459	\$503	\$548	1.50	36
48 x 30	HT4830YY	\$435	\$489	\$577	\$666	3.00	43
48 x 36	HT4836YY	\$449	\$518	\$607	\$695	3.00	47
48 x 42	HT4842YY	\$464	\$548	\$650	\$725	3.00	49
48 x 48	HT4848YY	\$480	\$576	\$665	\$753	3.00	50
48 x 60	HT4860YY	\$512	\$530	\$727	\$815	3.00	67
62 x 12	HT6212YY	\$407	\$435	\$494	\$553	2.00	33
62 x 18	HT6218YY	\$425	\$457	\$526	\$584	2.00	35
62 x 24	HT6224YY	\$441	\$499	\$558	\$617	2.00	46
62 x 30	HT6230YY	\$455	\$531	\$635	\$747	3.80	49
62 x 36	HT6236YY	\$501	\$564	\$672	\$780	3.80	56
62 x 42	HT6242YY	\$521	\$600	\$708	\$816	3.80	61
62 x 48	HT6248YY	\$540	\$631	\$739	\$848	3.80	67
62 x 60	HT6260YY	\$580	\$699	\$807	\$915	3.80	76
80 x 12	HT8012YY	\$473	\$542	\$612	\$683	2.40	37
80 x 18	HT8018YY	\$495	\$562	\$632	\$703	2.40	39
80 x 24	HT8024YY	\$518	\$583	\$653	\$724	2.40	62
80 x 30	HT8030YY	\$540	\$716	\$857	\$999	4.80	65
80 x 36	HT8036YY	\$562	\$736	\$877	\$1,019	4.80	80
80 x 42	HT8042YY	\$585	\$757	\$898	\$1,040	4.80	85
80 x 48	HT8048YY	\$611	\$780	\$922	\$1,063	4.80	95
80 x 60	HT8060YY	\$656	\$820	\$962	\$1,103	4.80	975

Open Market Only  
Not on GSA Schedule

## A1 FABRIC HALF GLAZED PANEL - NO RACEWAY

### Product Description

Upper section glazed, lower section fabric covered hard surface panel.  
Includes (1) panel.

**PANEL CONNECTORS MUST BE ORDERED SEPARATELY.**

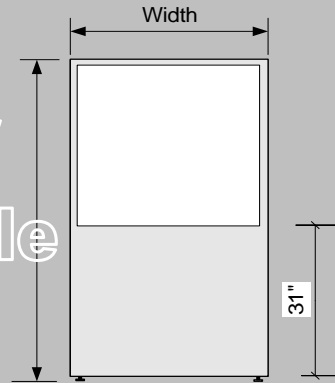

### Actual Dimensions

Depth (Thickness)	2"
Width	24", 30", 36", 42" & 48"
Height (Minimum)	62" & 80"

Open Market Only  
Not on GSA Schedule

## A1 FABRIC HALF GLAZED PANEL - NO RACEWAY

HALF GLAZED FABRIC PANEL WITH CHOICE OF BRONZE OR CLEAR GLAZING

### Specify:

- \* Product number.
- \* Trim color – "YY" (BU, DT, HT, LG, LT, MT)
- \* Glazing color (BR= Bronze, CL= Clear).

### Note:

- \* Order Finished End (Pg. 67) to finish exposed panel end.
- \* Order Panel Connectors (Pgs. 66-67)
- \* Fabric yardage estimate is for directional application (minimum 66" usable width).
- \* Special fabrics may affect yardage requirements.

### PANEL WITH BRONZE GLAZING

DIMENSION: H x W	ITEM NUMBER	FABRIC Q COM LIST	FABRIC GRADE 1 LIST	FABRIC GRADE 2 LIST	FABRIC GRADE 3 LIST	YDG REQ'D	WEIGHT
62 x 24	MGBR.6224YY	\$1,193	\$1,210	\$1,269	\$1,328	2.00	38
62 x 30	MGBR.6230YY	\$1,205	\$1,226	\$1,334	\$1,442	3.80	42
62 x 36	MGBR.6236YY	\$1,217	\$1,241	\$1,349	\$1,457	3.80	49
62 x 42	MGBR.6242YY	\$1,466	\$1,494	\$1,602	\$1,710	3.80	54
62 x 48	MGBR.6248YY	\$1,772	\$1,803	\$1,911	\$2,019	3.80	59
80 x 24	MGBR.8024YY	\$1,326	\$1,365	\$1,435	\$1,506	2.40	43
80 x 30	MGBR.8030YY	\$1,340	\$1,375	\$1,516	\$1,658	4.80	56
80 x 36	MGBR.8036YY	\$1,341	\$1,391	\$1,532	\$1,673	4.80	71
80 x 42	MGBR.8042YY	\$1,702	\$1,751	\$1,892	\$2,034	4.80	76
80 x 48	MGBR.8048YY	\$1,985	\$2,034	\$2,176	\$2,317	4.80	87

### PANEL WITH CLEAR GLAZING

DIMENSION: H x W	ITEM NUMBER	FABRIC Q COM LIST	FABRIC GRADE 1 LIST	FABRIC GRADE 2 LIST	FABRIC GRADE 3 LIST	YDG REQ'D	WEIGHT
62 x 24	MGCL.6224YY	\$1,193	\$1,210	\$1,269	\$1,328	2.00	38
62 x 30	MGCL.6230YY	\$1,205	\$1,226	\$1,334	\$1,442	3.80	42
62 x 36	MGCL.6236YY	\$1,217	\$1,241	\$1,349	\$1,457	3.80	49
62 x 42	MGCL.6242YY	\$1,466	\$1,494	\$1,602	\$1,710	3.80	54
62 x 48	MGCL.6248YY	\$1,772	\$1,803	\$1,911	\$2,019	3.80	59
80 x 24	MGCL.8024YY	\$1,326	\$1,365	\$1,435	\$1,506	2.40	43
80 x 30	MGCL.8030YY	\$1,340	\$1,375	\$1,516	\$1,658	4.80	56
80 x 36	MGCL.8036YY	\$1,341	\$1,391	\$1,532	\$1,673	4.80	71
80 x 42	MGCL.8042YY	\$1,702	\$1,751	\$1,892	\$2,034	4.80	76
80 x 48	MGCL.8048YY	\$1,985	\$2,034	\$2,176	\$2,317	4.80	87

## A1 DOOR PANEL - NO RACEWAY

PANEL CAN BE ORDERED WITH A LEFT OR RIGHT HAND SWINGING DOOR. ORDER DOOR FOR USE WITH AO1 PANELS ONLY THAT HAVE EITHER NO WIRE MANAGEMENT OR USE AO1 WIRE MANAGEMENT.

### Specify:

- \* Product number.
- \* Door color - (DT, HT, LG, LT, MT)
- \* Trim color - "YY" (BU, DT, HT, LG, LT, MT)
- \* Bronze or clear glazing.

### Note:

- \* Includes laminated door, bronze or clear glazed side panel, painted steel frame and locking door knob with hardware.
- \* Shipped assembled, except for lockset.
- \* Lock set must be field installed.

ITEM DESCRIPTION	ITEM NUMBER	HEIGHT	WIDTH	LIST PRICE	WEIGHT
------------------	-------------	--------	-------	------------	--------

For Use Without Wire Management

LEFT-HAND DOOR	HMDPAL.8048YY	80"	48"	\$3,275	105
RIGHT-HAND DOOR	HMDPAR.8048YY	80"	48"	\$3,275	105

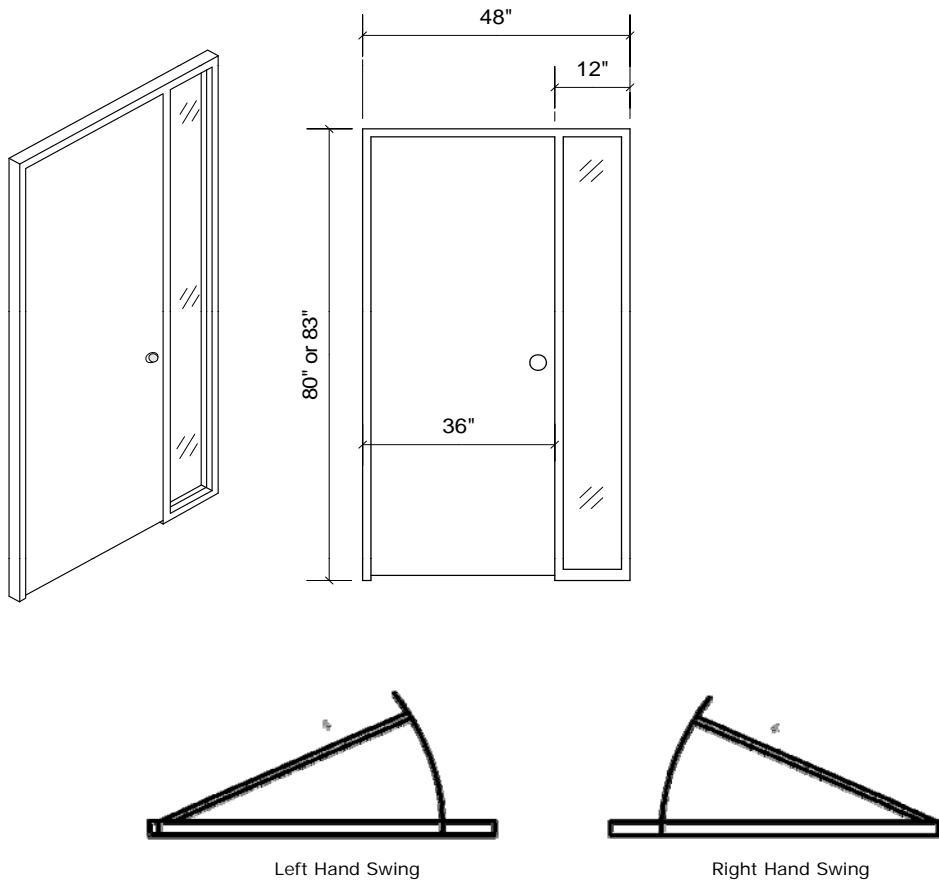



## A1 PANEL CONNECTORS - NO RACEWAY

### Specify:

- \* Product number.
- \* Trim color – "YY" (BU, DT, HT, LG, LT, MT)

### TWO WAY 90 CONNECTOR

CONNECTS TWO PANELS AT 90 DEGREES.

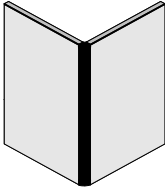

DIMENSIONS HEIGHT	ITEM NUMBER	LIST PRICE	WEIGHT
34"	HM2C.34YY	\$126	4
42"	HM2C.42YY	\$137	5
48"	HM2C.48YY	\$140	6
62"	HM2C.62YY	\$151	8
80"	HM2C.80YY	\$164	9

### THREE WAY CONNECTOR

CONNECTS THREE PANELS AT A "T".

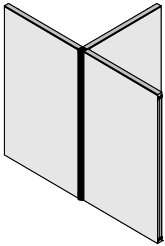

DIMENSION: HEIGHT	ITEM NUMBER		WEIGHT
34"	HM3C.34YY	\$184	6
42"	HM3C.42YY	\$200	7
48"	HM3C.48YY	\$210	8
62"	HM3C.62YY	\$230	9
80"	HM3C.80YY	\$259	11

### FOUR WAY CONNECTOR

CONNECTS FOUR PANELS AT AN INTERSECTION.

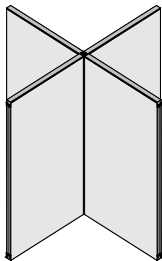

DIMENSION: HEIGHT	ITEM NUMBER		WEIGHT
34"	HM4C.34YY	\$181	7
42"	HM4C.42YY	\$210	8
48"	HM4C.48YY	\$215	9
62"	HM4C.62YY	\$249	10
80"	HM4C.80YY	\$269	13

### TWO WAY 180 DEGREE CONNECTOR

JOINS PANELS OF EQUAL OR UNEQUAL HEIGHTS FOR DIMENSIONAL GAIN.

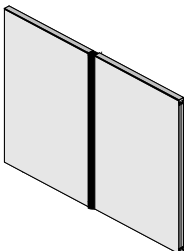

DIMENSION: HEIGHT	ITEM NUMBER		WEIGHT
34"	HM180C.34YY	\$232	6
42"	HM180C.42YY	\$251	7
48"	HM180C.48YY	\$264	8
57"	HM180C.57YY	\$277	9
62"	HM180C.62YY	\$287	9
80"	HM180C.80YY	\$322	11

## A1 PANEL CONNECTORS - NO RACEWAY

**Specify:**

- \* Product number.
- \* Trim color – "YY" (BU, DT, HT, LG, LT, MT)

### PANEL CONNECTOR ROD - DT ONLY

USED TO CONNECT TWO PANELS IN A STRAIGHT LINE.

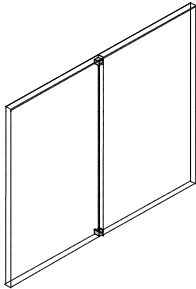

DIMENSIONS HEIGHT	ITEM NUMBER	LIST PRICE	WEIGHT
34"	HMPC.34	\$35	1
42"	HMPC.42	\$36	1.5
48"	HMPC.48	\$36	1.5
62"	HMPC.62	\$37	1.75
80"	HMPC.80	\$39	2

### T-CONNECTOR (WALL START)

CONNECTS PANEL TO AN EXISTING STRUCTURAL WALL TO BEGIN A PANEL RUN INCLUDES ONE (1) CONNECTOR ROD (SEE ABOVE)  
ORDER WALL FASTENERS (See Below) SEPARATELY.

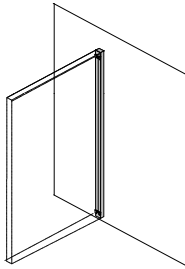

DIMENSION: HEIGHT	ITEM NUMBER	LIST PRICE	WEIGHT
34"	HMTC.34YY	\$85	6
42"	HMTC.42YY	\$89	6
48"	HMTC.48YY	\$92	7
62"	HMTC.62YY	\$98	8
80"	HMTC.80YY	\$103	9
ANCHOR KIT (4)	HMWF.4	\$16	2

### FINISHED END

FINISHES EXPOSED PANEL END.

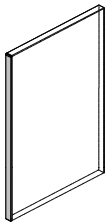

DIMENSION: HEIGHT	ITEM NUMBER	LIST PRICE	WEIGHT
34"	HMEC.34YY	\$55	4
42"	HMEC.42YY	\$59	6
48"	HMEC.48YY	\$60	6
62"	HMEC.62YY	\$64	7
80"	HMEC.80YY	\$69	9

## A1 PANEL COMPONENTS

### Specify:

\* Product number.

\* Trim color – "YY" (DT, HT, LG, LT, MT), NOT AVAILABLE ON WALL STRIPS

### WALL HANGER STRIP

HIGH QUALITY BRUSHED ALUMINUM EXTRUSIONS, WITH HEAVY DUTY 16 GAUGE STEEL SLOTTED INSERT IS USED TO HANG COMPONENTS OR WORK SURFACES DIRECTLY FROM A WALL. ORDER WALL FASTENERS (SEE BELOW) SEPARATELY. NATURAL ALUMINUM COLOR ONLY. PRICING IS PER STRIP, PICTURE SHOWS APPLICATION ONLY.

ITEM DESCRIPTION	ITEM NUMBER	LIST PRICE		WEIGHT
60" WALL HANGER STRIP	HMWHS.60	\$92	Each Strip	4
72" WALL HANGER STRIP	HMWHS.72	\$98	Each Strip	4
84" WALL HANGER STRIP	HMWHS.84	\$108	Each Strip	4

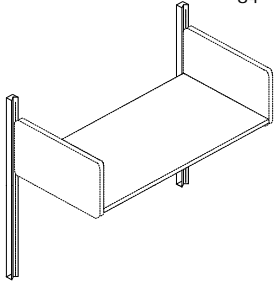

### WALL FASTENERS

USE TO FASTEN A T-CONNECTOR OR WALL HANGER STRIP TO AN EXISTING WALL..

ITEM DIMENSION	ITEM NUMBER	LIST PRICE	WEIGHT
3/16" TOGGLE BOLT ANCHOR	HMWF.1	\$3	1
3/16" x 3" FLAT HEAD TOGGLE BOLT	HMWF.2	\$1	1
ANCHOR KIT (12)	HMWF.3	\$49	12

### VARIABLE HEIGHT FILLER STRIP - RIGID

FINISHES EXPOSED END OF CONNECTOR OR PANEL WHEN JOINING PANELS OF DIFFERENT HEIGHTS. CUT TO LENGTH AS REQUIRED.

ITEM DESCRIPTION	ITEM NUMBER	LIST PRICE	WEIGHT
VARIABLE HEIGHT PKG - 4' LENGTH	HMVHYY	\$29	1

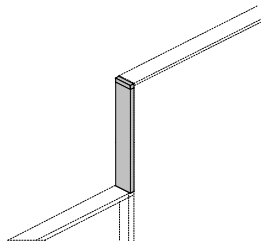





## MIRAGE PEDESTALS AND COMPONENTS

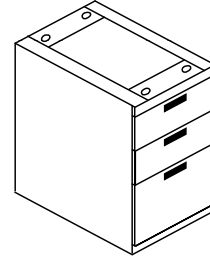

### CONSTRUCTION

- All-welded steel frame construction, formed in key areas for strength.
- Inner top and side panels consist of 18 - 21 gauge cold-rolled steel.
- Outer wrapper and drawer bin are 22 gauge, drawer fronts are 20 gauge steel.
- Vertical and Horizontal steel channels are reinforced for stability.
- Files and Pedestals include 4 leveling glides to insure proper drawer operation.
- Products are designed to meet or exceed BIFMA Standards. Lateral Files require counterweights to meet BIFMA Standards

### LOCKS

- Pedestals include LL Series, silver-faced, master-keyed, core removable locks.
- Cabinets are shipped with randomly-assigned keys and cores.
- For key-alike requests. There is a service charge for this. Key alike must be ordered at time of order entry or additional cost will apply  
Key alike must be ordered at time of order entry or additional cost will apply

### FINISHES

- Standard metal finishes are either an epoxy polyester powder, electrostatically applied, or a high-solids baked enamel paint finish. (Color Dependent)

### COUNTERWEIGHTS

- Freestanding, mobile and cushion peds are shipped with a counterweight installed.
- Counterweights are not necessary for worksurface supporting and hanging pedestals.
- Freestanding desking pedestals include a counterweight installed to ensure desk stability.

### SUSPENSION

- Steel Ball Bearing Full Suspension File Drawers. Box Drawers are 3/4 roller bearing suspension.
- 6" drawer dividers, 12" drawer dividers that allow for side-to-side filing, and pencil trays are sold separately.

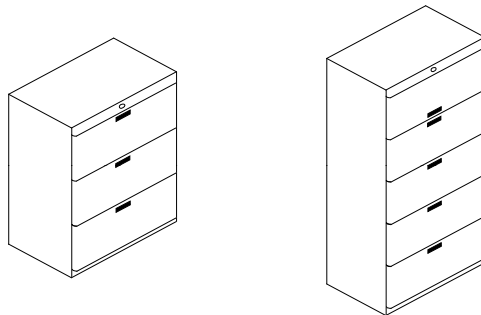

## MIRAGE METAL FRONT PEDESTALS

### Specify:

- \* Product number.
- \* Product color - "YY" (BU, DT, HT, LG, LT, MT)

### Note:

- \* Pedestals come with a lock and have radius metal drawer fronts.
- \* All files are 15.19" wide.
- \* Box drawers have ball-bearing slides.
- \* File drawers have full extension.
- \* Support Pedestals have fully adjustable 1" leveling legs.

DIMENSION: H x D	ITEM NUMBER	LIST PRICE	WEIGHT
---------------------	----------------	---------------	--------

### VALUE SERIES WORK SURFACE SUPPORTING PEDESTAL 27.75" H

Note: Available in BU and MT Finishes only. Locks on this item cannot be keyed alike, random key only.

#### 20" DEEP

FILE/FILE	VPED20.1212BU	\$515	66
BOX/BOX/FILE	VPED20.6612BU	\$515	66

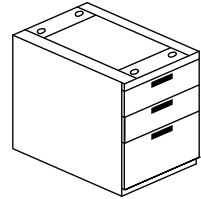

### METAL FRONT PEDESTAL HANGING PEDESTAL

BOX/FILE 18"D	HP18.612YY	\$510	45
BOX/FILE 22"D	HP.612YY	\$514	45

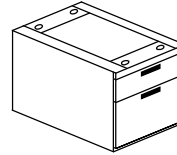

### WORK SURFACE SUPPORTING PEDESTAL 27.75" H

#### 18" DEEP

FILE/FILE	WSP18.1212YY	\$608	55
BOX/BOX/FILE	WSP18.6612YY	\$654	58

#### 22" DEEP

FILE/FILE	WSP.1212YY	\$613	59
BOX/BOX/FILE	WSP.6612YY	\$659	65

#### 28" DEEP

FILE/FILE	WSP28.1212YY	\$803	75
BOX/BOX/FILE	WSP28.6612YY	\$850	85

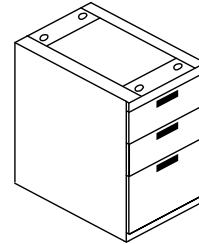

### MOBILE PEDESTAL 27"H

#### 22" DEEP

BOX/FILE	MP.612YY	\$695	45
FILE/FILE	MP.1212YY	\$824	70
BOX/BOX/FILE	MP.6612YY	\$876	70

#### 28" DEEP

FILE/FILE	MP28.1212YY	\$865	79
BOX/BOX/FILE	MP28.6612YY	\$968	85

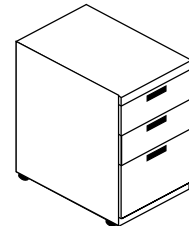

### DRAWER DIVIDER FOR METAL PEDESTALS

METAL PARTITION SLIDES INTO PRE-MEASURED AND PRE-CUT DRAWER SLOTS. FINISH: BLACK ONLY.

ITEM DESCRIPTION	ITEM NUMBER	LIST PRICE	WEIGHT
BOX DIVIDER - 6"	BDD	\$15	1
FILE DIVIDER - 12"	FDD	\$22	1
UTILITY TRAY - 6"	UT6	\$18	1

### KEY ALIKE OPTION FOR PEDESTALS/FILES/CABINETS/FLIPPER DOORS.

ITEM DESCRIPTION	ITEM NUMBER	LIST PRICE	WEIGHT
Key Alike	HMKA	\$19	1

# MIRAGE METAL STORAGE CABINETS AND TOWERS

**Specify:**

- \* Product number.
- \* Product color - "YY" (BU, DT, HT, LG, LT, MT)

**Note:**

- \* Files are equipped with center lock, full extension slides, and leveling legs.
- \* Includes drawer interlock feature.
- \* Meets or exceeds BIFMA standards.

ITEM DESCRIPTION	ITEM NUMBER	LIST PRICE	WEIGHT
------------------	-------------	------------	--------

**STORAGE CABINETS 36"W 17 3/8"D**

2 HIGH UNIT 28"	HMEST.2836	\$1,476	105
3 HIGH UNIT 40"	HMEST.4036	\$1,583	125
4 HIGH UNIT 52"	HMEST.5236	\$1,847	150
5 HIGH UNIT 64"	HMEST.6536	\$2,313	175
Replacement She	HMEST.SHELF36	\$107	12



ITEM DESCRIPTION	ITEM NUMBER	LIST PRICE	WEIGHT
------------------	-------------	------------	--------

**STORAGE TOWERS 24"W 3 DRAWER, 25" SIDE CABINET**

Tower w 3 File Drawer 64"h LH	HMESWL.6524FFF	\$3,245	200
Tower with 3 File Drawer 64"h RH	HMESWR.6524FFF	\$3,245	200

**5 STORAGE UNIT**

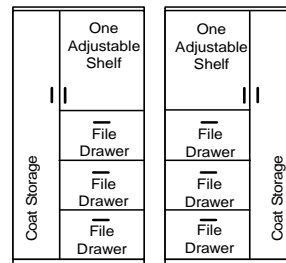

LH

RH

**STORAGE TOWERS 24"W 2 DRAWER, 37" SIDE CABINET**

Tower w 2 File Drawer 64"h LH	HMESWL.6524FF	\$3,142	198
Tower with 2 File Drawer 64"h RH	HMESWR.6524FF	\$3,142	198

**4 STORAGE UNIT**

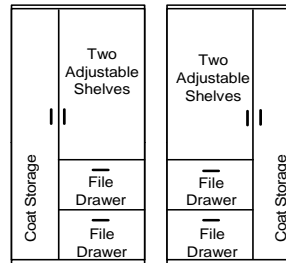

LH

RH

**STORAGE TOWERS 24"W 2 BOX DRAWERS, 1 FILE DRAWER, 37" SIDE CABINET**

Tower w 2 Box 1 File Drawer 64"h	HMESWL.6524BBF	\$3,245	200
Tower w 2 Box 1 File Drawer 64"h	HMESWR.6524BBF	\$3,245	200

**2 BOX/FILE STORAGE UNIT**

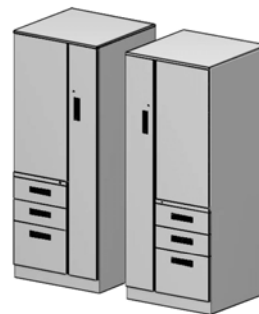

RH

LH

**KEY ALIKE OPTION FOR PEDESTALS/FILES/CABINETS/FLIPPER DOORS.**

ITEM DESCRIPTION	ITEM NUMBER	LIST PRICE	WEIGHT
------------------	-------------	------------	--------

Key Alike	HMKA	\$19	1
-----------	------	------	---

## MIRAGE METAL BOOKCASES AND WARDROBE CABINET

**Specify:**

- \* Product number.
- \* Product color - "YY" (BU, DT, HT, LG, LT, MT)

**Note:**

- \* Files are equipped with center lock, full extension slides, and leveling legs.
- \* Includes drawer interlock feature.
- \* Meets or exceeds BIFMA standards.

ITEM DESCRIPTION	ITEM NUMBER	LIST PRICE	WEIGHT
<b>BOOKCASE UNITS 36"W 13 3/8"D</b>			
2 HIGH UNIT 28"	HMEBT.2836	\$1,039	70
3 HIGH UNIT 41"	HMEBT.4136	\$1,093	85
4 HIGH UNIT 54"	HMEBT.5436	\$1,211	105
5 HIGH UNIT 66"	HMEBT.6736	\$1,345	125
6 HIGH UNIT 79"	HMEBT.7936	\$1,420	140
Replacement Shelf	HMEBT.SHELF36	\$95	12

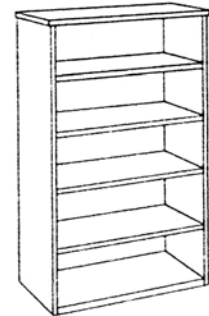

ITEM DESCRIPTION	ITEM NUMBER	LIST PRICE	WEIGHT
<b>WARDROBE UNIT WITH COAT ROD 36"W 13 3/8"D</b>			
5 HIGH UNIT 64" no shelves	HMESW.6536	\$2,102	180

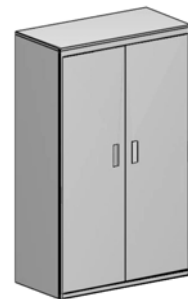

**KEY ALIKE OPTION FOR PEDESTALS/FILES/CABINETS/FLIPPER DOORS.**

ITEM DESCRIPTION	ITEM NUMBER	LIST PRICE	WEIGHT
Key Alike	HMKA	\$19	1

# MIRAGE METAL FRONT LATERAL FILES

**Specify:**

- \* Product number.
- \* Product color - "YY" (BU, DT, HT, LG, LT, MT)

**Note:**

- \* Files are equipped with center lock, full extension slides, and leveling legs.
- \* Includes drawer interlock feature.
- \* Meets or exceeds BIFMA standards when used with counterweight or anchored to wall.

**TWO DRAWER LATERAL 27 3/4"H 17 3/8"D**

DIMENSION: WIDTH	ITEM NUMBER	LIST PRICE	WEIGHT
30"	2DLF.30YY	\$1,196	85
36"	2DLF.36YY	\$1,306	110
42"	2DLF.42YY	\$1,428	122

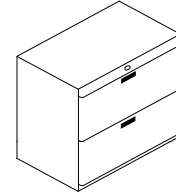

**TWO DRAWER WITH COUNTERWEIGHT**

30"	2DLFC.30YY	\$1,559	100
36"	2DLFC.36YY	\$1,670	115
42"	2DLFC.42YY	\$1,791	135

**THREE DRAWER LATERAL 39 3/4"H 17 3/8"D**

DIMENSION: WIDTH	ITEM NUMBER	LIST PRICE	WEIGHT
30"	3DLF.30YY	\$1,567	100
36"	3DLF.36YY	\$1,720	130
42"	3DLF.42YY	\$1,849	160

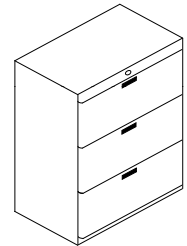

**THREE DRAWER WITH COUNTERWEIGHT**

30"	3DLFC.30YY	\$1,828	135
36"	3DLFC.36YY	\$1,982	155
42"	3DLFC.42YY	\$2,110	185

**FOUR DRAWER LATERAL 52"H 17 3/8"D**

DIMENSION: WIDTH	ITEM NUMBER	LIST PRICE	WEIGHT
30"	4DLF.30YY	\$1,873	150
36"	4DLF.36YY	\$2,105	175
42"	4DLF.42YY	\$2,343	205

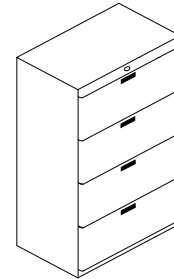

**FOUR DRAWER WITH COUNTERWEIGHT**

30"	4DLFC.30YY	\$2,058	175
36"	4DLFC.36YY	\$2,291	205
42"	4DLFC.42YY	\$2,502	225

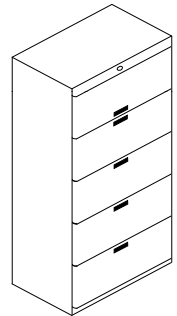

**FIVE DRAWER LATERAL 64"H 17 3/8"D, INCLUDES COUNTERWEIGHT**

DIMENSION: WIDTH	ITEM NUMBER	LIST PRICE	WEIGHT
30"	5DLF.30YY	\$2,412	240
36"	5DLF.36YY	\$2,704	270
42"	5DLF.42YY	\$2,982	310

**FILE CENTER 18 1/2" Deep**

DIMENSION: WIDTH	ITEM NUMBER		LIST PRICE	WEIGHT
30.5"	FC66.1230YY	BBF/LAT30	\$1,513	105
30.5"	FC12.1230YY	FF/LAT30	\$1,523	100
36.5"	FC66.1236YY	BBF/LAT36	\$1,523	115

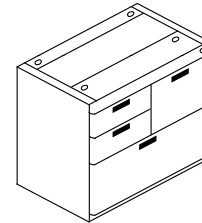

FC66.1230

**LATERAL FILE CONVERSION BAR - BK ONLY**

LFCB		\$8	1
Bars Needed:	30"	2 per drawer	
	36"	2 per drawer	
	42"	2 per drawer legal, 4 per drawer letter.	



**KEY ALIKE OPTION FOR PEDESTALS/FILES/CABINETS/FLIPPER DOORS.**

ITEM DESCRIPTION	ITEM NUMBER	LIST PRICE	WEIGHT
Key Alike	HMKA	\$19	1

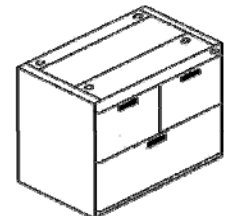

FC12.1230

## MIRAGE ACCESSORIES

### Specify:

- \* Product number.
- \* Product color - BK-BLACK ONLY

### Note:

- \* Tasklight includes a switch, 9' power cord assembly and fluorescent bulb.
- \* For use under standard 12" deep Shelf.

### TASKLIGHT

COMPLETE WITH MOUNTING BRACKETS - READY TO INSTALL



DIMENSION: LENGTH	ITEM NUMBER	LIST PRICE	WEIGHT
21.5"	TL.24BK For 24" and 30" Shelves	\$187	7
33.5	TL.36BK For 36" and 42" Shelves	\$201	9
48.5	TL.48BK For 48" and 60" Shelves	\$211	12

### CORD MANAGER

3/4" EXTRUDED PLASTIC LATCH CHANNEL IS USED TO CONCEAL CORDS ABOVE OR BELOW WORK SURFACE. AVAILABLE IN 4' LENGTHS. BLACK ONLY.



ITEM DESCRIPTION	ITEM NUMBER	LIST PRICE	WEIGHT
CORD MANAGER	ACM.4	\$23	1

### PAPER MANAGEMENT

TOOL BAR WITH VARIOUS ATTACHING COMPONENTS CAN BE USED FOR ORGANIZING A WORK AREA BY CREATING ACCESSIBLE STORAGE ABOVE THE WORK SURFACE. TOOL BAR IS MADE OF EXTRUDED ALUMINUM. COMPONENTS ARE INJECTION MOLDED, HIGHLY DURABLE PLASTIC.

### Specify:

- \* Product number.
- \* Product color - "YY" (BK)



Paper Tray

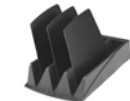

Folder Holder



Binder Holder



Pencil Holder

ITEM DESCRIPTION	ITEM NUMBER	LIST PRICE	WEIGHT
24" WIDE TOOL BAR	ATB.26BK	\$129	3
30" WIDE TOOL BAR	ATB.30BK	\$149	3
36" WIDE TOOL BAR	ATB.36BK	\$170	3
42" WIDE TOOL BAR	ATB.42BK	\$180	4
48" WIDE TOOL BAR	ATB.48BK	\$190	4
Tool Bar 60" WIDE TOOL BAR	ATB.60BK	\$242	4
10" WIDE PAPER TRAY	APT.YY	\$27	1
HANGING FILE FOLDER HOLDER	AHFF.YY	\$15	1
FOLDER HOLDER	AFH.YY	\$52	1
BINDER HOLDER	ABH.YY	\$27	1
PENCIL HOLDER	APH.YY	\$15	1

## MIRAGE ACCESSORIES

**Specify:**

- \* Product number.
- \* Product color - BK-Black Only

**Note:**

- \* Includes hardware for mounting.

### PENCIL DRAWER

DRAWER HAS FOUR COMPARTMENTS CONSTRUCTED FROM STURDY FORMED PLASTIC, WITH EASY MOUNTING BALL BEARING DRAWER SLIDES.

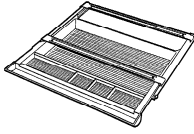

ITEM DESCRIPTION	ITEM NUMBER	LIST PRICE	WEIGHT
PENCIL DRAWER	HMPDBK	\$90	4

### FOR THE COMPUTER:

**Specify:**

- \* Product number.
- \* Product color Black only.

**Note:**

- \* Mounts easily under the worksurface providing additional work area and added computer operator support.

### KEYBOARD TRAYS

INCLUDES A FULLY ARTICULATING ARM - 15 DEGREE TILT, 5.75" UP/DOWN, 17.75" IN/OUT.

ITEM DESCRIPTION	ITEM NUMBER	LIST PRICE	WEIGHT
ADJUSTABLE ARTICULATING KEYBOARD WITH WRIST REST	AKBTWR	\$395	14
KEYBOARD WITH WRIST REST AND SWIVEL MOUSE	AKBTWRSM	\$467	20
KEYBOARD WITH WRIST REST AND SWIVEL/TILT MOUSE	AKBTWRSMT	\$507	22

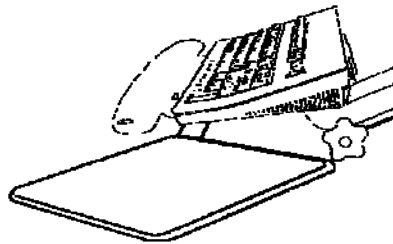
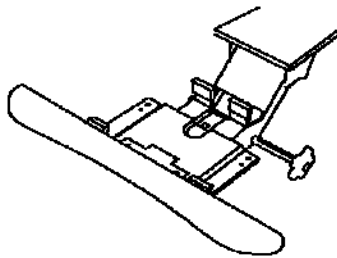

### PERIPHERAL ACCESSORIES

ITEM DESCRIPTION	ITEM NUMBER	LIST PRICE	WEIGHT
------------------	-------------	------------	--------



CPU HOLDER

CPU

\$327

25

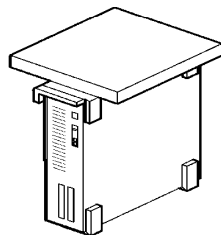

## MIRAGE ACCESSORIES

### Specify:

\* Product number.

### MARKERBOARDS

Includes mounting brackets, DT Edge Trim.

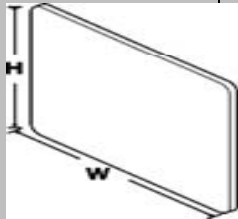

DIMENSION: H x W	ITEM NUMBER	LIST PRICE	WEIGHT
24 x 24	HMMB.2424	\$350	45
24 x 48	HMMB.4824	\$438	80
36 x 36	HMMB.3636	\$500	65
48 x 48	HMMB.4848	\$711	110

Open Market Only  
Not on GSA Schedule

### Specify:

\* Product number.

\* Product color - "YY" (BU Only)

### DATA/VOICE COVERS & JACKS

USE WITH POWERED OR NONPOWERED PANELS (SEE BELOW). COVERS CAN ALSO BE USED WITH CUSTOMER'S JACKS. CHECK WITH FACTORY FOR APPLICATION. COVERS FIT IN RECEPTACLE OPENINGS ON POWERED COVERS. SPECIFY PANEL ACCORDINGLY.

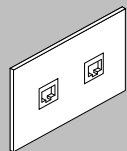
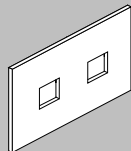

ITEM DESCRIPTION	ITEM NUMBER	LIST PRICE	WEIGHT
COVER ONLY WITH TWO SQUARE HOLES FOR RJ-11 OR RJ-45 JACKS	DJC.YY	\$14	1
COVER WITH ONE RJ-11 & ONE RJ-45 JACK INCLUDED. CAT 5e Specification	DJC.RJ11RJ45	\$195	1
COVER WITH ONE RJ-11 & ONE RJ-45 JACKS INCLUDED. CAT 6 Specification	DJC6.RJ11RJ45	\$200	1
COVER WITH TWO RJ-45 JACKS INCLUDED. CAT 5e Specification	DJC.RJ45RJ45	\$243	1
COVER WITH TWO RJ-45 JACKS INCLUDED. CAT 6 Specification	DJC6.RJ45RJ45	\$250	1