

■ General Information

This installation manual provides necessary information for the safe installation of the Mirage product.

WARNING: Failure to follow the instructions in this manual can result in product damage, personal injury or both.

The Mirage product line is a modular panel system composed of panels, hanging and freestanding components and accessories designed to be precisely tailored to the office environment. It consists of product that are factory assembled and require installation only; and other products that are shipped as subassemblies for assembly during the installation process. The Mirage products are available with an 8 wire electric system that is listed with Underwriters Laboratories and complies with UL1286. Therefore, check with local authorities before installing this product.

WARNING: Installation of electrical components should be done by a qualified electrician. Disconnect power prior to servicing the system. Failure to do so can result in electric shock and/or personal injury.

It is the responsibility of the dealer and the installer to properly install this product according to this manual and generally accepted industry practices. This product is considered portable furniture and is therefore subject to local fire, electrical and building codes. Therefore, check with local building authorities before installation of the product. Should you have questions or require assistance during the installation process, please telephone our support center at (800)598-7278 (Monday thru Friday, 8:00 am to 5:00 PM ET).

■ General Tools for Install

The following tools are necessary for field assembly and installation of the Mirage product.

1. Allen wrench 1/4"
2. Screwdriver #2 phillips head
3. Screwdriver #3 phillips head
4. Screwdriver, med slotted
5. Measuring Tape (25' or more)
6. Rubber mallet or dead blow mallet

■ Staging

In addition the following tools will help and speed up installations.

1. Carpenter's Level (48")
2. Drill (12V or more)
3. Set of drill bits
4. Set of screw bits #2 & #3
5. Wrench open end 10 mm (long handle is best)
6. Pliers
7. Carton knife
8. Ratchet head with 1/4" allen bit

■ Product Assembly

Panels/Connectors.....	3
Electrical.....	5
Storage/Shelves/Flippers.....	10
Work surfaces.....	11
Pedestals and File Cabinets.....	13
Accessories.....	14
Dimensioning & Stability.....	16

■ Special Notes

- Please note all warnings, these are for your safety.
- Use proper tools when installing.
- Keep your work area clean, clutter free and safe during installation.
- Use eye protection when working under a workstation or when working with tools.
- Note: many products weigh more then 35 lbs, use 2 or more people to safely lift, carry and install the products.
- When using tools, extension cords or ladders use them in accordance with manufacturer's recommended procedures.



Typical finished installation of the Mirage product.

■ Panel and Connector Installation - Definitions

1. A panel run is any combination of two or more panels connected in a straight line.
2. Panels mounted at right angles to panel runs are called support panels. The minimum height for support panels should be not less than 1/2 the height of the tallest panel in the panel run. (For example: 85" high panel run should have a minimum of a 47" high support panel.)
3. Load bearing walls also known as structural walls. They are constructed of materials such as poured concrete, concrete block or drywall properly attached to metal or wood studs. Drywall must be at least 5/8" thick. Wall must be restrained at the floor and ceiling and should be no more than 24" on center or 14' high.
4. UNDER NO CIRCUMSTANCES does Mirage Office Furniture accept responsibility for determination of the structural integrity of a load bearing wall.
5. A loaded panel run is any panel run that has product components of any kind attached to it. Also shown as "load bearing side of a panel run".

NOTE: All panels with electrically interconnected panels must be mechanically interconnected.

WARNING: Check panels for stability after installation of all components. Verify that all product is properly level and correctly attached. If needed, correct or adjust leveling or installation to fix stability. If needed, add additional support panels for additional stability.

Panel runs should be installed straight and parallel to each other (see figure 1.1).



figure 1.1



figure 1.2



figure 1.3



figure 1.4



figure 1.5

■ Panels and Connectors - Part 1

Tools required: 1/4" allen wrench, 10mm open end wrench.

Installation:

Start at a right angle condition in your layout. It is recommended that you identify the location using your plan to locate the connection in the office area.

Step 1. Using a 2, 3 or 4 way connector, loosen the draw block at the top (finished end) of the connector with your allen wrench (figure 1.2). The connector should easily fit over the panel wedge blocks on the end of your first panel (figure 1.3). Tighten connector on to panel (figure 1.4).

Step 2. Add a second panel on to the connector by loosening the other draw block at the top of the connector (figure 1.2). Install the panel in a similar manner to step 1 (figure 1.5) and you have the start of your first station (figure 1.6).

WARNING: It is recommended that you have one person hold the panels, while you install the two panels and connector together.

NOTE: It is recommended at this point that you begin to level the product to help in the installation and make the leveling process easier.



figure 1.6

■ Panels and Connectors - Part 2

Step 3. Using your panel plan as reference, determine where the next panel goes. Install the panel in a panel run as follows. Using the rod & block, open the rod so it will loosely fit over your panel you have installed (figure 2.1). With the help of another installer add the next panel in a straight line (figure 2.2). Make sure the bottom and the top of the panel are aligned with your other panel, adjust the panel glides if needed (figure 2.5). Tighten rod & block to connect the two panels (figure 1.2).

Step 4. Install the finished end cap. To install the finished end cap, loosen the top of the end cap (1 hole) with your allen wrench (figure 2.6). Set the bottom of the end cap (3 holes) on the bottom wedge block on the panel (figure 2.5). Move the end cap up and set over the top block of the panel (figure 2.6). Tighten end cap on panel (figure 2.7).

Step 5. Level panels as required (figure 2.8). Turn leveling glide with 10 mm wrench to adjust as needed. Also, realign your panels for location and square in the installation. Refer to your installation plans for location. Double check your work now, it will save time later. Level both to the earth, but also visually.

TIP: Use the ceiling tiles to help line up the visual aspects of your installation.



figure 2.1



figure 2.2



figure 2.3



figure 2.4



figure 2.5



figure 2.6

■ Panels and Connectors - Wall Starts

Step 6. Wall start applications require some additional tools. The most important are a good tape measure, level and a drill. The wall should be reinforced to prevent damage or injury. Locate on your plan the wall start. Measure the wall and very lightly with a pencil mark the location of the wall start. Take a panel and level it to the wall to determine the mounting height of the wall start. Lightly mark the wall at the top of the panel. Locate the top 2 holes of the wall start and mark on the wall for positioning. After lining up the location of the wall start, mount the top block first - this is the smaller of the 2 blocks - (figure 3.1) Install your fastener to the wall at this location and install the top of the wall start. Next level the wall start and repeat this step on the remainder of the wall start. Next attach the bottom block (figure 3.2). Cut and attach the filler strip as needed (figure 3.4).



figure 2.7



figure 2.8



figure 3.1



figure 3.2



figure 3.4

■ Panels and Connectors - Variable Height

Step 7. When installing a variable height connection you must remove the trim on the side of the connector you are going to attach at a variable height (always use the connector for the tallest panel you are attaching to). Remove the black filler strip from the side of the connector you want to lower (figure 4.1). To remove the filler strip squeeze it at one end and pull toward you. Once the trim is removed you need to unbolt the top wedge block assembly on the side you are lowering (figure 4.2). Use a #3 phillips screw driver to do this. Once the block is removed, remove the connector top cap by pressing gently on the location pin to release it (figure 4.3). Using the back of the filler strip, push the threaded plate on to the sticky tape (align to fit in connector). Place threaded connector plate on the back side of the filler strip to use as an alignment guide for installation (figure 4.4). Using the filler strip as your guide insert the threaded plate into the connector to the desired height connection (figure 4.5). At the appropriate location, reinstall the connector wedge block to create your variable height condition (figure 4.6). Reinstall the connector top wedge block using the existing screws and parts. When the wedge block is securely tightened in place, gently pull on the filler strip to release it. Using a carton knife or a cutting tool, cut the filler strip to the appropriate length and reinstall the filler strip on the connector.

Step 8. To install your variable height condition, attached the connector to your existing panel run. Use 2 people if needed. Attach connector to existing panel run and attach the next panel in the run. Generally, it is easiest to attach panels of similar height (figure 4.7). Using a standard allen wrench or a ratchet, attach the panels in the variable height location (figure 4.8). Tighten the panel wedge block to finish the installation (figure 4.9).

■ Panels and Connectors - Variable Height Trim

Step 9. To install the variable height trim, take the trim strip and place it upside down on the connector, measure the length to the top and draw a line to mark for cutting. Using a small hack saw or other appropriate cutting tool, cut the trim to length and remove the paper from the tape (figure 4.1.1). Align with the variable height location on the connector (figure 4.1.2) and press into place (figure 4.1.3).

NOTE: If you remove the trim strip to change or adjust the panel you may need to replace the double sided tape.



figure 4.1.1



figure 4.1.2



figure 4.1.3

■ Panel Leveling WARNING

WARNING: It is very important at this point in the installation to RECHECK ALL CONNECTIONS to insure safety and security. In addition, now is the time to level the system and align the stations to the plan. The panels can generally slide on the floor as needed. It may take a few people to move it at this point. Check to make sure you are not scratching or binding on the flooring material; you can damage it if you are not careful. Carefully take time to line up all aspects of the job at this point as it will help during the rest of the installation.



figure 4.1



figure 4.3



figure 4.5



figure 4.7



figure 4.2



figure 4.4



figure 4.6



figure 4.8



figure 4.9

■ Energy Installation - Definitions

1. Electrical packs are the power distribution parts that carry all power through the Mirage system.

2. Power Entry, either base feed or ceiling feed are the power distribution parts designed to connect to the existing building power.

WARNING: Never attempt to install the power entries on this system without a qualified electrician. Attempting to do so can result in electric shock, personal injury or death.

3. Pass through jumpers are similar to the electrical pack and carry power through the Mirage system.

4. Receptacles are the outlet plugs designed for installation in the electrical packs to provide power near the work space.

5. Festoons are the pass through jumpers used to power the electrical packs from electrical pack to electrical pack.

6. Qualified electrician is an individual either licensed or recognized by the local building code authorities to properly wire the Mirage power system to the existing building power.

WARNING: Never attempt to service this electrical system without first disconnecting all power to the system. Attempting to do so can result in electric shock, personal injury or death.

WARNING: This energy system is designed to be installed in accordance with all local building codes. It must not be install contrary to these codes for any reason.



figure 5.1



figure 5.2

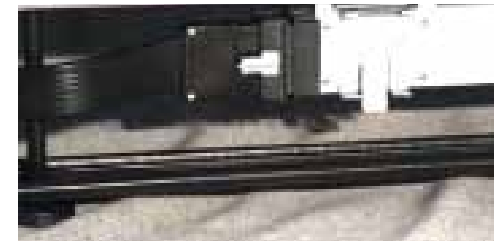

figure 5.3

■ Energy - Festoon Installation

Step 1. Once you have installed the panels and connectors and have leveled the system you can begin to install the festoons. There are two types: panel to panel and panel through post to panel, both install in a similar manner. Under no circumstances should you ever install 2 festoon on both sides of 2 connecting electrical packs or on all 4 sides of a 4 way connection or on a 3 sides of a 3 way connection or on 2 sides of a 2 way connection. (SEE DRAWING ON PAGE 6) This condition WILL CAUSE a short circuit. Place the festoon gently into one end of the panel electrical pack and push until it locks into the silver locking mechanism. Note the up arrow for locating the direction (figure 5.1). Make sure the clip is locked over the festoon to secure it. (figure 5.2). Repeat the step on the next panel.

WARNING:

The arrow on the festoon must be in the UP position.



figure 5.4

■ Energy - Receptacle Installation

Step 2. Install the receptacle gently into the side of the electrical pack with the number or letter in the up position (figure 5.4). Align the lower tab on the receptacle with lock the receptacle into the energy harness (figure 5.5).

WARNING: You must secure the receptacle at this point in the installation. Failure to do so can cause an electrical hazard.



figure 5.5

■ Energy - Pass Through Jumper Installation

Step 3. Pass through jumper installation is very similar to the festoon installation, except you may pass through a combination of panels and connectors. One note: you must use a pass through jumper 6" longer when connecting through a 2, 3, 4 way or 180 degree connector. Under no circumstances should you ever install 2 pass through jumpers on both sides of 2 connecting electrical packs or on all 4 sides of a 4 way connection or on a 3 sides of a 3 way connection or on 2 sides of a 2 way connection. (SEE DRAWING ON PAGE 6) This condition WILL CAUSE a short circuit. Place the festoon gently into one end of the panel electrical pack and push until it locks into the silver locking mechanism (3.2). Make sure the clip is locked over the pass through jumper on each end to secure it (figure 6.1). Repeat the step on the next panel in your plan.



figure 6.1

NOTE: Use the up arrow for locating the direction of the pass through jumper.

■ Energy - WARNING for Festoon and Pass Through Jumper

WARNING: Failure to follow these directions for connecting both festoon and pass through jumper cables can cause a short circuit and may result in product damage, electrical shock, property damage or personal injury.

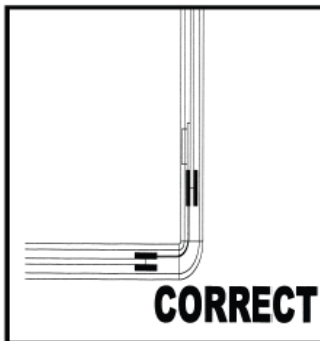

figure 6.2

Step 4. When connecting festoon jumpers or pass through jumpers you must take care to not connect the power system back into itself. See the attached drawings for the correct installation of the following conditions:

- A. 2 way connections
- B. 3 way connections
- C. 4 way connections

Correct Installations



Correct 2 way installation

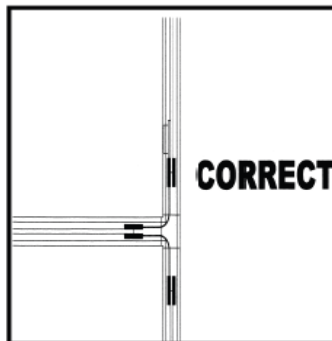

Correct 3 way installation

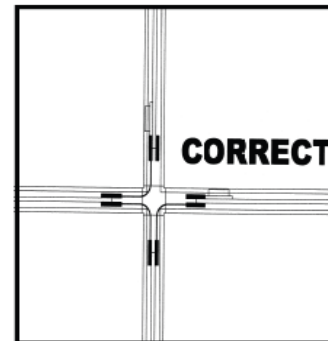

Correct 4 way installation

Incorrect Installations

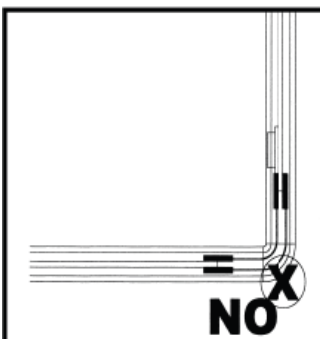

WARNING: WRONG, DO NOT INSTALL LIKE THIS

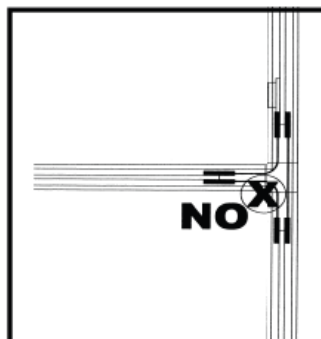

WARNING: WRONG, DO NOT INSTALL LIKE THIS

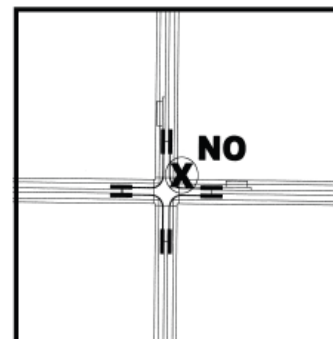

WARNING: WRONG, DO NOT INSTALL LIKE THIS

■ Energy - Power Entry, Ceiling Feed

Step 5. To install the ceiling feed, gently push ceiling feed into the end of an electrical pack and engage locking clip. Make sure the locking clip is engaged to secure the ceiling connection

NOTE: The installation of the power entries both ceiling feed and base in feed must be done by a qualified electrician. The purpose of this description of the installation is to assist you in working with the electrician in having this product installed. UNDER NO CIRCUMSTANCES, should this be attempted by a person not recognized by local building authorities as a qualified electrician.

WARNING: Power Entries should not be installed by any person(s) other than a qualified electrician. Attempting to do so can result in electric shock, personal injury or death.

To install the ceiling feed gently push ceiling feed into the end of an electrical pack and engage locking clip (figure 7.1). (see next dia- Make sure the locking clip is engaged to secure the ceiling feed (figure 7.2).



figure 7.1



figure 7.2

■ Energy - Wiring Diagram for Ceiling and Base in Feed

This diagram is the general wiring diagrams for both the ceiling in feed and the base in feed (see next page). The diagram will vary depending on local codes, the buildings general wiring type and specific applications for use. In general, the WYE type application is used in most single phase office type applications. Before wiring you should ALWAYS consult a qualified electrician for the specific diagram to use in your facility.

WARNING: Power Entries should not be installed by any person(s) other than a qualified electrician. Attempting to do so can result in electric shock, personal injury or death.

Wiring Schematic 8-Wire UL1286

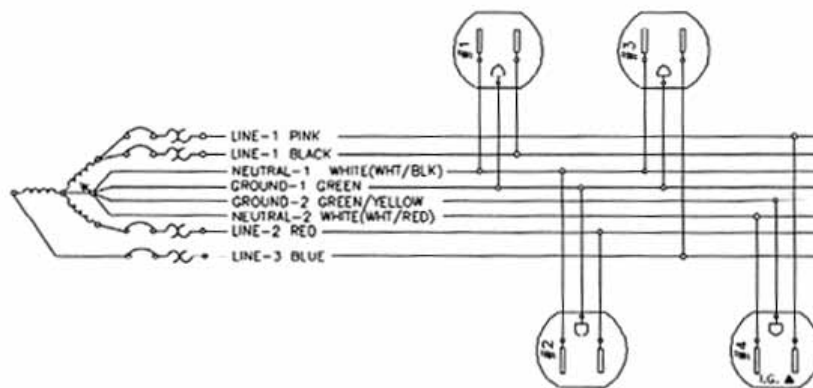

120/208V. WYE

■ Energy - Base in Feed

NOTE: The installation of the power entries both ceiling feed and base in feed must be done by a qualified electrician. The purpose of this description of the installation is to assist you in working with the electrician to have this product installed, UNDER NO CIRCUMSTANCES, should this be attempted by a person not recognized by local building authorities as a qualified electrician.

Step 6. To install the base in feed, gently push the Base in feed into the side of the electrical pack. Push and lock into the spring clip on the bottom of the power harness. (figure 8.1)

TIP: You should feed the cable through your electrical opening.

Make sure the clip is locked over it to secure it. Connect cable into wall or floor at a junction box in accordance with local building codes and the wiring diagram on the previous page.

WARNING: Power Entries should not be installed by any person (s) other than a qualified electrician. Attempting to do so can result in electric shock, personal injury or death.

■ Energy - Connector Trim Installation

For 2 & 3 way and 180 degree connectors only, 4 way connectors do not have trim.

Step 7. To begin installing the connector trim pieces, gently place the ends of the specific connector trim over the tabs on the end of the connector stem. (figure 8.2 and 8.3). You may have to bend the cover slightly to place it over the tab. Use caution to avoid breakage. (figure 8.4). Connector trim will stay in place when finished (figure 8.5).

■ Energy - Raceway Cover installation

Once the power is installed and the connector trim covers are on you can begin installation of the raceway covers.

Non-powered raceway

Step 8. To install non-powered raceway, gently push the groove in the bottom of the raceway cover (starting at one end) on to the rolled edge of the bottom of the raceway (figure 8.6). Take care to line up the ends of the raceway covers. Roll the cover up into position to lock into the lower... (figure 8.7). Gently tuck the lip on the top of the raceway cover under the metal edge at the panel. (figure 8.8). When finished the raceway cover will stay in place (figure 8.9).

NOTE: At this point you may want to encourage the data and telephone installers to lay their cable, it can be done later, but generally works well at this point.



figure 8.1



figure 8.3



figure 8.5



figure 8.7



figure 8.2



figure 8.4



figure 8.6



figure 8.8



figure 8.9

Powered raceway

Step 9. All installation of the powered raceway covers is identical to the procedure listed for the non powered raceway covers except the alignment with the receptacles or the base in feed are critical for installation (figure 9.0). Also, once in place, you should immediately insert the outlet covers in all locations where outlets or base in feeds are not present. This can be done either before or during raceway cover installation (figure 9.1). Once alignment is complete (figure 9.2 and 9.3), install like the non-powered covers.



figure 9.0



figure 9.1

■ Energy - Raceway End Cap

Step 10. To install the raceway end cap, locate the tabs at the bottom of the raceway end cap (3 tabs). Place the tabs into the holes in the raceway at an end cap location (figure 9.4).

NOTE: The end cap must be installed first.

Rotate the end cap up to the bottom of the panel (figure 9.5) and lock into place on the indentation on the underside of the panel at the top of the raceway. If needed use a flat tip screw driver to gently adjust the tab (figure 9.7).



figure 9.2



figure 9.3

■ Shelves - End Installation

The following installation instructions are for open shelves. This instruction is for standard height, low height or EDP depth. It is also the beginning stage of installation for a flipper door.

Step 1. Begin the shelf installation by placing the rear of the shelf end at a slight angle to the panel, about 85 degrees (figure 9.4). Insert the bracket at the rear of the shelf end into the slots on the panel and rotate the shelf end to 90 degrees to the panel. You should feel the shelf end drop into place, if you do not, you should gently tap the shelf end downward to lock into place. It is a good idea to install all shelf ends in a given cubical at this point (figure 9.8). Move all shelf ends 90 degrees to the panels at this point to begin the next step of the installation (figure 9.9).

WARNING: Make sure the shelf end is secure at this point. When installing the shelf and/or flipper door, this will be critical.

WARNING: Make sure the shelf ends are secure at this point before proceeding to this next step.



figure 9.4



figure 9.5



figure 9.6



figure 9.7



figure 9.8



figure 9.9

■ Shelf Pan Installation

Step 2. To install the shelf pan you first need to insert the shelf bolts into the shelf ends. If you are installing only a shelf, insert 4 bolts. If you are going to also install a flipper door, insert 8 bolts at this point. With the rectangular slot towards you, gently set the back of the shelf on the 2 lower rear screws (figure 10.1). Pivot the front of the shelf on to the front screws (figure 10.2). If you are only installing a shelf, use a #2 phillip screw driver to tighten all 4 screws at this point to secure the shelf to the shelf ends (figure 10.3) OR If you are going to install a flipper door or an additional shelf to this pair of shelf ends do not tighten the screws at this point, proceed to the next step.

WARNING: Check to make sure the shelf is securely locked on to the shelf ends. If you are proceeding to install a flipper door or additional shelf, you must repeat this process to insure the security of the shelf.

■ Flipper Door Installation

Step 3. The installation of the flipper door is similar to a shelf. You must insert the bolts on the shelf end first. While holding the door in place, set the rear of the flipper door on to the rear shelf bolts at the top of the shelf (figure 10.4), rotate the door onto the front bolts (figure 10.5). Tighten all bolts at this point, including the shelf pan bolts, to make your flipper door secure (figure 10.6).

NOTE: You may need to loosen the shelf bolts. You may need to move the door slightly to access the rear bolts (figure 10.7)

■ Work surface Installation - Definitions

1. **Support Arm:** The "cantilever" arm used to mount the work surface to the panel or wall strip.
2. **Work surface:** The top or surface used at the desk.
3. **Transaction top:** The top surface used at a counter type installation.
4. **Flat plate:** A ganging plate used for stabilizing and locking 2 work surfaces together.

WARNING: The correct installation of a work surface or transaction top is mandatory. You must make sure during all phases of this installation that ALL parts are installed correctly and are secure. Failure to do so could result in product damage or personal injury.

■ Standard Work Surface Support Arm Installation

Step 1. Measure location off floor for correct mounting height (figure 10.8) Your location off the floor will vary depending upon your application. Verify the dimension using a pedestal as reference or specific instructions from your customer as to the desired height. Generally, about 27 1/2-28" is the best selection, but this will vary depending upon the job site conditions. Begin by inserting the clip at the rear of the support arm into the hanger frame on the side of the panel (figure 10.9). Push arm firmly into hanger frame, use a small mallet to insure proper insertion (figure 10.10).

NOTE: Be careful do not damage the painted finish.

It is recommended that you install all support arms in a given station prior to work surface installation.



figure 10.1



figure 10.2



figure 10.3



figure 10.4



figure 10.5



figure 10.6



figure 10.7



figure 10.8



figure 10.9



figure 10.10

■ Work Surface Corner, Bracket installation

Step 1. On the Corner Work surfaces you must install the rear corner bracket prior to installing the work surface. To do this locate the bracket (figure 11.1) at the same height as the support arm. Place the upper tab of the bracket into the hanger frame of the panel in the corner and rotate it into place (figure 11.2).



figure 11.1



figure 11.2

■ OEM Work Surface Support Arm Installation

Step 1. Measure location off floor for correct mounting height (figure 11.3) Your location off the floor will vary depending upon your application. Verify the dimension using a pedestal as reference or specific instructions from your customer as to the desired height. Generally about 27 1/2-28" is the best selection, but this will vary depending upon the job site conditions. Begin by inserting the clip at the rear of the support arm into the hanger frame on the side of the panel (figure 11.4). Push arm firmly into hanger frame, use a small mallet to insure proper insertion (figure 11.5).

NOTE: Be careful to not damage the painted finish.

It is recommended that you install all support arms in a given station prior to work surface installation (figure 11.6).



figure 11.3



figure 11.4

■ Work Surface Retainer Bracket for OEM Style Support

Step 2. The next step is to install the work surface retainer bracket on the under side of the work surface.

NOTE: There are 2 types of retainer brackets for the OEM support arms, one has a pointed sharp end, the other is square on both ends. The retainer that is pointed is used on ALL surfaces, the retainer that is square on both ends is used on one side of a corner work surface. Install this bracket using the 3/4" pan head screws provided.

Align the bracket with the tabs at the rear of the work surface. Place the screws in the first hole from the rear (figure 11.7). Make sure the pointed tab is at the rear (figure 11.8). On corner work surfaces, use the bracket without the tabs at the rear. Install on one side, use the standard bracket on the other side (figure 11.9) Install all brackets with the 3/4" pan head screw provided (figure 11.10).



figure 11.5



figure 11.6

■ Work Surface Installation Standard Support Arms

To install the standard work surface on to the standard support arms, begin as follows: Using two people, set the work surface into place on the support arms and align the mounting holes to the mounting holes on the support arms. Install the 3/4" pan head screws provided in all mounting holes.

NOTE: At this time you may find it necessary to adjust the alignment of the panels to get the work surfaces to align properly. This needs to be done now to prevent problems in the next few stations you are installing.



figure 11.7



figure 11.8



figure 11.9



figure 11.10

■ Work Surface Corner Installation Standard Support Arms

On the standard work surface support arm installation the corner work surface is mounted in a similar fashion to the standard work surface with one exception. You must also mount the screws for the rear corner bracket at this time. Install support arms the same as the instructions for "Work Surface Installation Standard Support Arms" Install 3/4" pan head screws into the rear corner bracket to secure it (figure 12.1). After all brackets are secure, insert the corner work surface grommet into the top (figure 12.2). Press it into place using your hand or gently tap in with a small mallet (figure 12.3).



figure 12.1



figure 12.2

■ Work Surface Peninsula Installation Standard Support Arms

The peninsula support arms install the same as listed above. However, you must first install the peninsula leg (figure 12.4). You do this by locating the leg mid way on the end of the peninsula and attaching it with the 3/4" pan head screws provided.

WARNING: It is recommended when handling a peninsula that you use two people for safety.



figure 12.3



figure 12.4

■ Work Surface Installation OEM Support Arms

To install the work surface with the OEM Type Support Arms you must place the retainer brackets into the top of the support arm (figure 12.5) and gently slide the work surface back into the support arm at a slight angle until the front of the retainer bracket can drop into the support arm (figure 12.6). This will allow the work surface to engage in the support arm (figure 12.7).

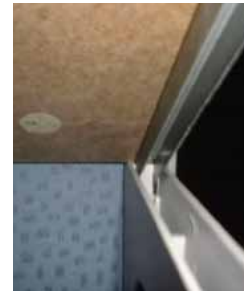

figure 12.5



figure 12.6

■ Work Surface Corner Installation OEM Support Arms

To install the corner work surface, you must place the retainer bracket with the tab at the rear into the support arm as shown in figure 12.5. Once this is done, move the work surface to align the other retainer bracket over the other support arm and drop into this support arm. After all brackets are secure, insert the corner work surface grommet into the top. Press it into place using your hand or gently tap in with a small mallet.

WARNING: This installation should always be done with two people or more.



figure 12.7



figure 12.8

■ Work Surface Installation Counter Caps

Installing a counter cap is generally a two person job. With one person holding the counter cap in the approximate location, hook the counter cap brackets upward into the panel hanger frame (figure 12.8). Align the hole in the top with the brackets and insert the 3/4" pan head screws (figure 12.9). Repeat this procedure on the other side of the counter cap and then at the other end (figure 12.0).



figure 12.9



figure 12.0

■ Work Surface Installation D Tops

Installation of D Tops varies depending on whether you have an island style or a work surface style.

A. Island style tops are installed like a freestanding table. Set the 3 legs on the 2 ends of the table and the center of the arc (figure 13.1). Install with 3/4" pan head screws. If you have ganging or mounting plates, install them at this time. When finished, turn the table over and place in your plan location (figure 13.2).

B. Work surface style tops install as follows: Install flat plates on the end of your existing work surfaces and tie the 2 or 3 surfaces together (figure 13.3). With the D Top up side down attach the peninsula leg to the top using 3/4" pan head screws. With the assistance of another person flip the top over and set on the flat plates. Align the top with your existing tops and secure the surfaces to each other.



figure 13.1



figure 13.2

■ Pedestals

All pedestals except mobile pedestals require attachment to the work surface they are hanging from or supporting. It is important that you checked your pedestal height in "Work surface Installation". If the height is incorrect you will have to reset the height of the work surfaces accordingly. First step is to open the drawer on your pedestal (the key is attached to the drawer front for shipping). Remove the top 2 box drawers or the file and/or the box drawer depending on your configuration by lifting the dislodging bracket and pulling forward (figure 13.4). Using the screws provided. With the pedestal in place, attach the screws at the front and the rear of the pedestal to support it (figure 13.5). Carefully replace the drawers (figure 13.6).

NOTE: Always recheck the drawers for correct operation after installing the pedestal. Also check to make sure the lock works correctly.



figure 13.3



figure 13.4



figure 13.5



figure 13.6

■ Pencil Drawers Standard

The first step is to install the mounting brackets onto the side to the drawer slide (figure 13.7). Use the small pan head screw provided. Next with the drawer close, hold the drawer under the work surface at the desired location. Insert the mounting screws provided in the drawer kit into the work surface to complete the installation (figure 13.8). The drawer should fit just slightly under the edge of the surface (figure 13.9).

■ File Cabinets

All Lateral file cabinets and file centers are designed to be freestanding. They should ALWAYS be leveled. A slight rear tilt at the top of the cabinet can help with drawer closure. In areas prone to or suspected to have earthquake activity you should always mount these cabinets to the walls or a fixed object to prevent tip over during an earthquake. Cabinets can be ganged together for additional stability (figure 13.0).

WARNING: In earthquake areas you should anchor your cabinets to the walls or a fixed frame to prevent tipping. Consult your local building department for requirements.

WARNING: ALWAYS LEVEL FILING CABINETS, allow for a slight rear pitch to the cabinet if needed (figure 13.1.1).



figure 13.1.1



figure 13.7



figure 13.8

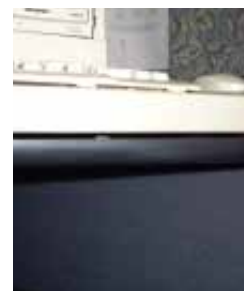

figure 13.9



figure 13.0

■ File Cabinet Front to back bars

Front to back filing is achieved by placing the lateral file conversion bars in the cabinets as shown figure 14.1 and 14.2. Insert the bar into the rear slot on the side to side hanging frame. Pushing the bar slightly back and then forward to align with the front of the cabinet.



figure 14.1



figure 14.2

■ Accessories

Tack Boards

Insert the tack board mounting brackets on to the panel hanger frame at the desired location (figure 14.3). Attach the shoulder screws to the tack board approximately 4" from the top of the tack board, about 1/2" in from the edge of the tack board the second screw is located exactly 7" below the first (figure 14.4). Slide the tack board screw into the tear drop of the tack board bracket and the top notch of the bracket (figure 14.5). Check to make sure the tack board is level (figure 14.6).



figure 14.3



figure 14.4

Tool Bars

Locate the tool bar mounting brackets to the correct width for the installation on to the panel. They should match the width on the center of the slots on the panel hanger frame. Once you have set the mounting brackets at the desired location, tighten the screw on the rear of the mounting brackets (figure 14.7). Push the mounting bracket into the hanger frame. Gently press down to engage the tool bar (figure 14.8).



figure 14.5



figure 14.6

Work Tools

All work tools required a tool bar of appropriate length. The tools have a small c-shaped clip at the rear. To insert the tool simply place at a slight angle to the bar and insert it. Drop into position. Attach work tools to the tool bar as needed, see figure 14.9 and 14.0 for examples.



figure 14.7



figure 14.8

Marker Boards

Install the mounting bracket on the panel at the appropriate location (figure 14.3). Next mount the shoulder screws into the rear of the marker board at the appropriate location (14.4). The screw should be 7" apart top to bottom. Attach the marker board over the tear drop and the upper notch of the mounting bracket (figure 14.5).

Under Counter Light

Remove the light diffuser from the fixture. Next remove the bulb. There are 2 mounting holes inside the task light body. Hold under the work surface and drill 2 3/4" pan head screw into the surface to mount (figure 14.1.1). Reinstall the bulb and the light diffuser. Use the cord managers to route the cord to the appropriate location (figure 14.1.2).



figure 14.1.1



figure 14.1.2



figure 14.9



figure 14.0

Cord Managers

The cord manger is sold in 4' lengths and designed to be cut to length in the field and place to manage and control cables in the stations. The following are examples of the use of the cord manger.



Cord manager used with tool bar.



A small section of cord manger used below a tack board.



Cord manger with tool bar and tack board.



A cord manger used for task light cord control.

Task Lights

Install the mounting bracket on the side of the tack light (figure 15.1). Once both brackets are in place, set the rear edge of the light and mounting bracket on the rear lip underneath the shelf or flipper unit (figure 15.2). Rotate up into place, move the front of the mounting bracket and snap into place under the shelf or flipper door (figure 15.3).



figure 15.1



figure 15.2



figure 15.3



figure 15.4



figure 15.5



figure 15.6

Data Ports

To install the data ports you must first insert your finish data jacks into the port (figure 15.4). Depending on the supplier of the jack you may have to adapt the port slightly to get the port to fit, please contact the factory for help. Insert both jacks into the port prior to installing it on the panel (figure 15.5). Once the jacks are installed in the port insert the port into the raceway cover on the bottom of the panel (figure 15.6).

NOTE: Some data jacks will not work in this port check with the factory for assistance.

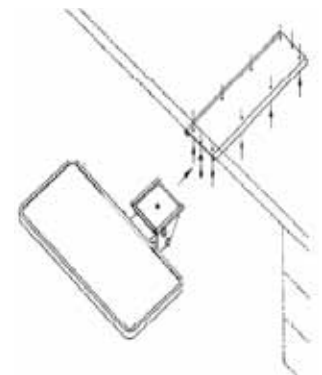

figure 15.7

Keyboard Arm

Install the metal track for the keyboard arm first to the under side of the work surface (figure 15.7). Next install the rear bumper using the screw and bumper provided to the rear center of the bracket. Install the keyboard arm and tray together (figure 15.8). Slide the keyboard arm on to the track and secure with bracket (figure 15.9)

NOTE: There are many different keyboard arms available, not all look like this. Please check the instruction with the arm first.



figure 15.8



figure 15.9

Product Stability

WARNING: The following notes are for your safety and the safety of your customer. Failure to read and follow these directions can result in product damage or personal injury

Panel Stability is very important the following do's and don'ts will make your project and safe installation. Please close attention to the dimension and examples on this page. They are here for your safety.

IN GENERAL: Do not exceed 8'-10' in length nor 24" in depth on any given panel run except as shown in figure 16.1. This will provide the maximum stability to the system.

LONGER RUNS: Do not exceed 12' in overall length, ALWAYS use 24" "wing" or stabilizing panels on BOTH ends of the run. Failure to do so can result in product damage or personal injury.

ALWAYS USE COMMON SENSE: See figure 16.2 and 16.3. When installing or designing a station, always counter the weight to where the "wings" or stabilizing panels are. DO NOT INSTALL THE WEIGHT TO THE OPPOSITE SIDE. This can result in product damage or personal injury.

LONGER RUNS: See figure below. On long panel runs use multiple "wing" or stabilizing panels every 8-10' to support the panels and the components hanging from them.

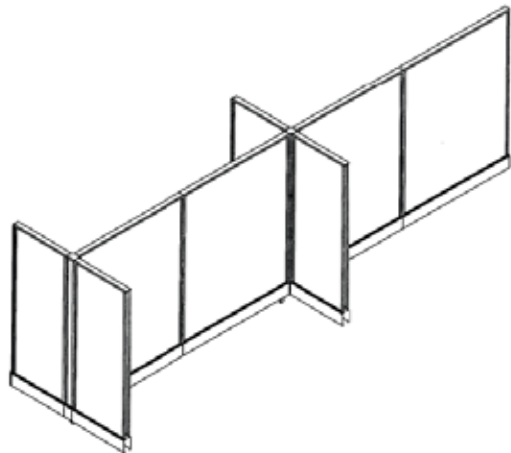

WALL STARTS: See figure 16.4. Do not exceed 8' off a wall start without adding a "wing" or stabilizing panel of 24" or more.

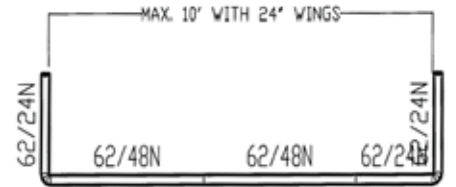

figure 16.1

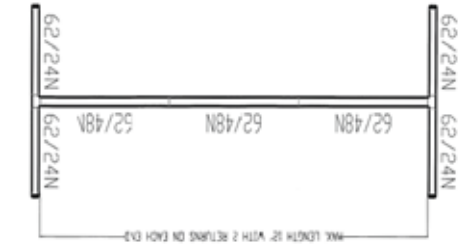

figure 16.2

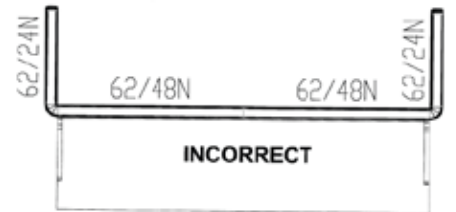

figure 16.3

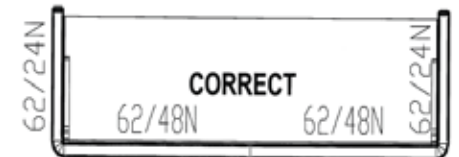

figure 16.4

■ Product Dimensions

Like most panel systems, this system experiences creep in dimension due to connectors, raceway covers, etc. Please note the following examples of dimensions for your installation. This is VERY critical when running in very tight locations or wall to wall applications. If you have additional questions please call Unisource at (800)598-7278 Monday - Friday 8:00 am to 5:00 PM ET

DIMENSION FOR 2 WAY 90 DEGREE (figure 17.1)

When making a 90 degree connection you must allow the following dimensions for panel creep.

Dim A: Actual panel width.

Dim B or C: Actual panel width

Connector AO1: 2.75" x 2.75"

Connector Mirage: 3.50" x 3.50" to allow for

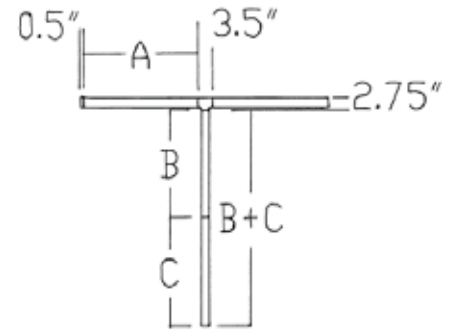

figure 17.1

DIMENSION FOR 3 WAY (figure 17.2)

When making a 3 way connection you must allow the following dimensions for panel creep.

Dim A: Actual panel width.

Dim B or C: Actual panel width

Connector AO1: 3.50" x 3.50"

Connector Mirage: 3.50" x 4.25" to allow for electrical trim.

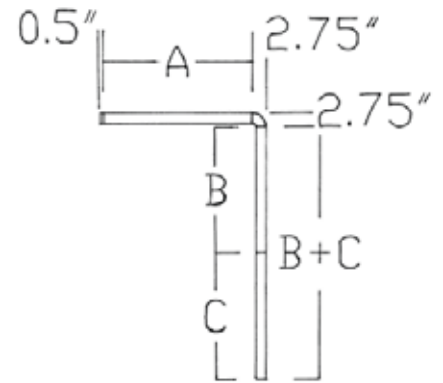

figure 17.2

DIMENSION FOR 4 WAY

Allow for both AO1 & Mirage 3.50" x 3.50"

Mirage Panel Note: Add 0.75" for the raceway

■ Wall Strip Dimensions

All dimensions are to the center of the wall strip.

Field height of the wall strip should be as follows: (Other conditions can occur use a qualified installer).

60' wall strip:

A1 Panel 62" high align to top of panel in field.

A2 Panel 62" high align to top of panel in field.

A2 Panel 67" high align to top of panel in field.

72' wall strip:

A1 Panel 80" high align to top of panel in field.

A2 Panel 85" high align to top of panel in field.

84" wall strip:

A2 Panel 85" high align to top of panel in field.

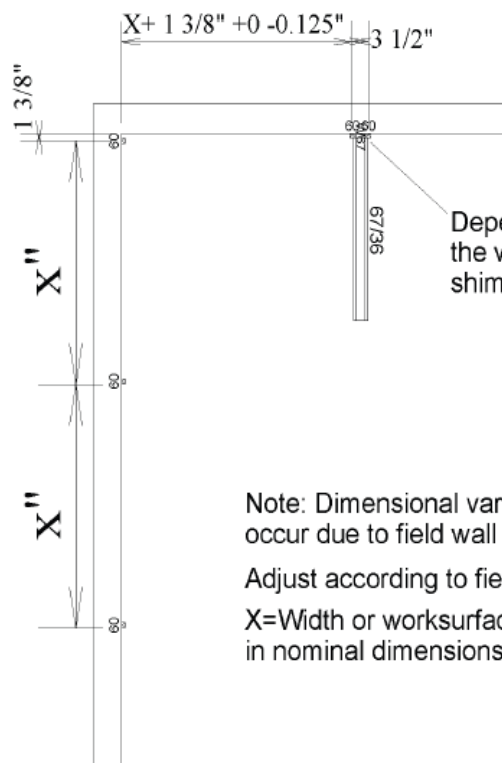

Note: Dimensional variations can occur due to field wall conditions

Adjust according to field conditions.

X=Width or worksurface or flipper door in nominal dimensions.

7377 Expressway Dr Unit #D
Grand Rapids, Michigan 49548 USA

1-800-598-7278
1-616-455-9400
1-616-455-9494

www.unisourceparts.com
customerservice@unisourceparts.com

This product is designed to be used for many years of general office service.
This installation manual will help in the proper installation of the product for use.

■ Examples of Installations

PRIVATE OFFICES



TEAM WORK ENVIRONMENTS



RECEPTION STATIONS



CENTRAL PRINTING AND FAXING



GENERAL OFFICES



SALES STATIONS

